



Department of the Environment and Heritage

Technical Report No. 2:
Polycyclic aromatic hydrocarbons
(PAHs)
in Australia

A consultancy funded by Environment Australia.

Prepared by Dr Henry N. Berko

Department of Environmental Protection

Perth, Western Australia

October 1999

An initiative of the Living Cities – Air Toxics Program

© Commonwealth of Australia June 2002
ISBN 0642547807
Published by Environment Australia, June 2002

The research reported in this document was commissioned by Air Toxics Section, Environment Australia under the Living Cities Program. It has been prepared by Department of Environmental Protection, Western Australia.

The report carries no formal endorsement by Environment Australia or the Australian Government nor should any be implied.

All care has been taken in collating and presenting the information contained; however, it is the user's responsibility to check the validity of any external references contained within this report.

Information contained in this publication may be copied or reproduced for study, research, information or educational purposes, subject to the inclusion of an acknowledgment of the source.

Printed on recycled paper.

A list of related Air Toxics reports and copies of these reports is available at our web site www.ea.gov.au/atmosphere/airtoxics.

Copies of Environment Australia publications, including this publication, may be obtained from:

Community Information Unit
Environment Australia
GPO Box 787
CANBERRA ACT 2601
Phone: 02 6274 1221
Freecall: 1800 803 772
e-mail: ciu@ea.gov.au

Environment Australia
Air Toxics Section
GPO Box 787
CANBERRA ACT 2601
e-mail: airtoxics@ea.gov.au
www.ea.gov.au/atmosphere/airtoxics

Executive Summary

Polycyclic aromatic hydrocarbons (PAHs) are released into the atmosphere, as a complex mixture of compounds during incomplete combustion of organic matter. Although hundreds of PAHs have been identified in atmospheric particles, toxicological endpoint and/or exposure data are available for only 33 PAHs. They are widespread contaminants of the environment and a number of them are either known or suspected carcinogens. Information on the fate and behaviour of PAHs in the air environment in Australia has been collected on an *ad hoc* basis and is located in a range of different organisations in different states.

The objective of this project was to undertake a desktop study of the state of knowledge of PAH concentrations in ambient air in Australia, and the sampling and analytical methods used. A comparison of sampling and analytical methods has been undertaken to provide information on the comparability of results from different jurisdictions.

There have been eight main studies of PAH concentrations in Australian cities since 1990. The studies reported here were done in: Brisbane (July 1994 to June 1995), Perth (April 1994 to July 1995), Darwin and Jabiru East (December 1994 to July 1997), Canberra (September 1996 to March 1997), Launceston and the Upper Tamar Valley (July 1991 to September 1993), Melbourne at Debney's Park (November 1990 to November 1991), at Footscray and Alphington (May to June, 1990) and then at Collingwood (January to December, 1993). A comprehensive study of PAHs has also been conducted in NSW, however the results were not available. Industrial self-monitoring data collected under conditions of NSW EPA discharge licences in 1996 and 1997 have been included in this report.

The most studied PAHs (with the maximum reported particulate phase concentrations and averaging times) were: benz(a)anthracene (15.3 ng/m³, 24h), benzo(a)pyrene (34.3 ng/m³, 24h), benzo(b)fluoranthene (22.2 ng/m³, 24h), benzo(g,h,i)perylene (38.7 ng/m³, 24h), benzo(k)fluoranthene (16.4 ng/m³, 24h), chrysene (15.1 ng/m³, 8h), dibenz(a,h)anthracene (2.4 ng/m³, 24h), fluoranthene (11.5 ng/m³, 24h), phenanthrene (9.00 ng/m³, 5d) and pyrene (20.0 ng/m³, 24h)—their concentrations have been reported in at least six studies. Benzo(a)pyrene was the most reported PAH, its concentration was reported in all the studies.

In most of the Australian studies, PAH emissions were attributed to domestic heating or other combustion activities prevalent during winter. The Launceston study recorded the highest benzo(a)pyrene concentration—34.3 ng/m³, during periods of high haze levels in winter.

At present, ambient PAH monitoring is being done by the NSW EPA and Environment ACT. The Environmental Aerosol Laboratory at the Queensland University of Technology, Queensland is engaged in PAH research.

Based on the literature reviewed, the presence of chrysene and benzo(k)fluoranthene may be indicators for coal combustion emissions. Whereas other PAHs are indicators of other combustion process: benzo(g,h,i)perylene, coronene and phenanthrene are indicators for motor vehicle emissions, pyrene and fluoranthene are associated with incineration and fluorene, fluoranthene and pyrene are associated with oil combustion. Indicators for road salt particles, from salting roads with salt, are phenanthrene, fluoranthene and pyrene. All these PAHs were identified in the Australian studies.

It was difficult to compare PAH levels between different jurisdictions, because of the varying methods used to determine them. There were several different sampling regimes used for collecting samples; however, more standardised methods were used for chemical analyses of PAH. In addition, different suites of PAH compounds were studied.

In most of the Australian studies, particulate phase PAH samples were collected onto glass fibre filters which were located on high volume samplers. The Brisbane study collected vapour phase PAHs, using solid adsorbents, in addition to the particulate phase PAHs. After collection, PAHs from most samples were extracted by ultrasonic agitation of the filters placed in polar solvents. Few studies used the traditional Soxhlet extraction method and only one study used supercritical fluid extraction (SFE) to extract the PAH samples. The extracted samples have to be cleaned, to remove other organic compounds, before chemical analysis for the PAHs. However, several of the studies did not report cleaning the extracts. PAHs were identified and quantified by GC/MS or HPLC, the former was the most popular choice for all the studies.

No standard or systematic measurement methods have been used in most of the studies across Australia. Since it is desirable to compare data across jurisdictions, this report presents recommendations for the sampling and measurement of PAHs.

PAH concentrations in Australian cities were comparable to similar data reported in the international literature. Winter PAH concentrations appear to be higher than summer concentrations by a factor of 2 to 5, and this differential has also been reported in overseas studies.

There are no ambient air quality standards for PAHs in Australia. However, the composite annual average concentration of benzo(a)pyrene in Australian cities appear to be below available European guidelines. The Dutch National Institute of Public Health and the Environment (DNIPHE) has recently determined maximum permissible concentrations (MPCs) for toxic compounds. These MPCs represent risk limits. The highest annual average benzo(a)pyrene concentration in two Australian cities, Perth and Launceston, were greater than the DNIPHE-calculated MPC value (1.0 ng/m^3) for benzo(a)pyrene, in ambient air.

The literature reviewed on health effects of PAHs, showed that most of the data collected on the human health effects of PAH exposure arise from epidemiological studies conducted in the occupational setting. There is evidence of a dose-response relationship between numerous PAHs and health endpoints, including lung cancer and depressed immune function, for coke oven workers exposed to PAHs. Long term exposure to PAHs can elevate the risk of various cancers and immunotoxic and respiratory problems.

Bioassay-directed chemical analysis has been used to determine PAH mutagenicities, with most studies employing bacterial assays as biological endpoints. Biological markers (biomarkers) such as PAH-DNA adducts, have also been used in several molecular epidemiology studies to assess PAH-exposure and effect.

There is a lack of research work investigating the complex issues involved in determining the health effects associated with PAH exposure in ambient air.

Glossary/Abbreviations

ANZECC	Australian and New Zealand Environment and Conservation Council
Bdl	Below detection limit
CE	capillary electrophoresis
CEC	capillary electrochromatography
DB	Debney's Park Estate at Flemington, Victoria
DCM	dichloromethane
DNIPHE	Dutch National Institute of Public Health and the Environment (RIVM)
EOC	equivalent organic carbon
EOF	electroosmotic flow
FID	flame ionisation detection
FL	fluorescence
FPM	fine particle mass
GC/MS	gas chromatograph/mass spectrometer
Hi-vol	high volume sampler
HPLC	high performance liquid chromatograph
IARC	International Association for Research into Cancer
IMF	induced mutant fraction
IPCS	International Programme on Chemical Safety
ISO	International Organisation for Standardisation
KD	Kuderna-Danish evaporator
LC	liquid chromatography
Lo-vol	low volume sampler
LVD	local visual distance
MAS	Melbourne Aerosol Study
MEKC	micellar electrokinetic capillary chromatography
MPC	maximum permissible concentration
MV	motor vehicle
NEPM	National Environment Protection Measure
NIST	National Institute of Standards and Technology (United States)
NOAEL	No Observed Adverse Effect Level
NSW EPA	New South Wales Environment Protection Authority
ODS	OctaDeca Silica (silica gel chromatography column)
PAC	polycyclic aromatic compounds (polynuclear aromatic compounds)
PAH	polycyclic aromatic hydrocarbons (polynuclear aromatic hydrocarbons)
PAS	photoelectric aerosol sensor
PM10	particulate matter with aerodynamic diameter of 10 microns or less
PTFE	polytetrafluoroethylene
PUF	polyurethane foam
SIM	select ion monitoring
SFE	supercritical fluid extraction
SSI	size selective inlet
THF	tetrahydrofuran
TSP	total suspended particle
US EPA	United States Environmental Protection Authority
UV	ultraviolet
WHO	World Health Organisation
XAD-2	Amberlite XAD-2 resin (styrene-divinylbenzene polymer resin)

{This page intentionally left blank}

TABLE OF CONTENTS

EXECUTIVE SUMMARY	III
GLOSSARY/ABBREVIATIONS	V
1. INTRODUCTION.....	1
1.1 Background.....	1
1.2 Objective.....	2
1.3 Scope.....	2
2. PAH EMISSION PROFILES	3
2.1 PAH Sources	3
2.2 Source Markers.....	4
2.2.1 Source Profiles.....	4
2.2.2 PAH Ratios	5
3. PAH STUDIES IN AUSTRALIAN CITIES (1990-1999)	6
3.1 Summary of Studies Conducted in each State	6
3.2 PAH Compounds Identified.....	7
4. COMPARABILITY OF SAMPLING AND ANALYTICAL METHODS	9
4.1 Sampling Methods	9
4.2 Analytical Methods.....	12
4.2.1 Extraction.....	12
4.2.2 Sample Clean-up.....	13
4.2.3 Instrumental Analysis	14
4.2.4 Electrophoresis Methods.....	16
4.2.5 Continuous PAH Analysers	16
4.3 Recommended Methods for Measuring PAHs.....	17
4.3.1 Recommended Sampling Method.....	17
4.3.2 Recommended Chemical Analysis Methods	19
5. PAH IDENTIFICATION AND CONCENTRATIONS IN AUSTRALIA	22
6. PAH WORK IN PROGRESS	27
7. COMPARISON OF AMBIENT PAH DATA IN AUSTRALIAN CITIES AND OTHER CITIES AROUND THE WORLD.....	28

8. HEALTH IMPACTS.....	31
8.1 Ambient Standards.....	31
8.2 Human Health Effects of Exposure to PAHs	32
8.3 PAH Potencies.....	34
8.4 PAH Mutagenicity	35
8.5 PAH Biomarkers.....	37
8.6 Ecological Impacts of PAHs.....	37
9. SUMMARY OF FINDINGS.....	38
10. REFERENCES.....	43
11. APPENDICES	51
Appendix A: List of Organisations/Individuals Contacted.....	51
A1. Environmental Agencies	51
A2. Other Government Agencies.....	51
A3. Research Institutions	52
Appendix B: Ring Structure of Selected PAHs.....	53
Appendix C: General Metal Works PAH Sampling Head.....	54
Appendix D: Apparatus Used in Sample Preparation	55

1. Introduction

1.1 Background

'Polycyclic aromatic hydrocarbons' (PAHs) are a complex class of organic compounds containing two or more fused aromatic rings, and containing only carbon and hydrogen atoms. The physical and chemical properties of PAHs are determined by their conjugated π -electron systems, which are dependent on the number of aromatic rings and the molecular mass (see Appendix B for the ring structure of some PAHs). The smallest member of the PAH family is naphthalene, a two-ring compound, which is found in the vapour phase in the atmosphere. Three to five ring-PAHs can be found in both the vapour and particulate phases in air. PAHs consisting of five or more rings tend to be solids adsorbed onto other particulate matter in the atmosphere. The term 'polycyclic aromatic compounds' or 'polycyclic organic matter' is used to include similar compounds with nitrogen, oxygen or sulfur substituents such as nitro-PAHs, hydroxy-PAHs and heterocyclic compounds. This report will concentrate only on compounds that fall in the category of polycyclic aromatic hydrocarbons. Sometimes the term 'polynuclear' is used in the literature instead of 'polycyclic' to describe these compounds.

PAHs are released into the atmosphere as a complex mixture of compounds during incomplete combustion of organic matter. They can be emitted from wood burning heaters, agricultural waste burning, motor vehicle exhaust, cigarette smoke, asphalt road and roofing operations. PAHs are widespread contaminants of the environment and a number of them are either known or suspected carcinogens. Benzo(a)pyrene, a widely reported five-ring PAH, is known for its carcinogenic potency. Although hundreds of PAHs have been identified in atmospheric particles (Lao *et al.*, 1973; Lee *et al.*, 1976), toxicological endpoint and/or exposure data are available for only 33 PAHs.

During the past ten years, a number of studies on polycyclic aromatic hydrocarbons in various Australian cities have been conducted. These studies identified and quantified several PAH compounds in samples collected from the air environment.

At present, there is no Australian standard method to be used for PAH monitoring. Further, since different suites of PAH compounds have been monitored in the various studies, it is very difficult to compare PAH levels in different Australian cities. Hence, there is currently no straightforward way of determining the comparability of data between jurisdictions. For example, the traditional method for PAH sample collection involves the use of a filter only. Although non-volatile PAHs would remain on the filters, semi-volatile PAHs would be lost as a result of post-collection volatilisation. Using solid absorbents to collect the vapour, in conjunction with filters, can reduce this loss.

Given the carcinogenicity of these PAHs and their presence in ambient air from a range of sources, a collation of available international and national information is required to enable the appropriate development of strategies to investigate the potential health impact of PAHs in air in Australia. A comparison of sampling and analytical methods is also required to provide information on the comparability of results from different jurisdictions.

This report covers the studies done in Australia, between 1990 and 1999, and utilises information gathered and reviewed for ANZECC (Victorian EPA, 1998; Denison, L.S., 1998).

1.2 Objective

The objective of this project was to undertake a desktop study of the State of Knowledge of PAH concentrations in ambient air in Australia.

1.3 Scope

The scope of the project was:

- To collate published and unpublished PAH information from environmental agencies in Australia.
- To obtain PAH information from other groups such as health agencies, academic and scientific institutions in Australia.
- To outline work in progress on PAH monitoring in Australia.
- To provide a critique on sampling and analytical methods used, to enable comparisons of concentrations between jurisdictions, and make recommendations.
- To undertake a literature review of reported PAH concentrations, the priority PAHs and potential health impacts.
- To write a report on the State of Knowledge of PAHs in Australia.

2. PAH Emission Profiles

2.1 PAH Sources

PAHs can be found in various compartments of the environment: air, surface water, sediment, soil, food and in lipid tissues of both aquatic and terrestrial organisms.

Natural emission sources of PAHs into the atmosphere include emissions from forests fires and volcanoes. Anthropogenic emission sources include combustion and industrial production. Only a few PAHs are produced for commercial use; these include naphthalene, fluorene, anthracene, phenanthrene, fluoranthene and pyrene (Franck and Stadelhofer, 1987). Emissions into the atmosphere during the production of these PAHs are not expected to be significant. Naphthalene, used as a moth repellent, because of its inherently high vapour pressure is the only PAH expected to be released directly into the atmosphere during use. In Western Europe, the 15000 tonnes of naphthalene produced annually would end up in the atmosphere, if all were used for moth repellent.

Atmospheric emissions will arise from the processing of coal and petroleum products and incomplete combustion during industrial processes such as aluminium production and incineration. Incomplete combustion from motor vehicles, domestic heating and forest fires are major sources of PAH in the atmosphere. During the cooling of exhaust emissions from combustion processes, PAHs are incorporated onto particles through a condensation and adsorption process (Broddin *et al.*, 1980). Thus they are normally associated with particulate matter, although a significant amount remain in the vapour phase.

Table 1. Airborne PAH Emissions during the Processing of Coal & Petroleum Products

Emissions Source	Typical Emissions/Profiles
Coal Coking	B(e)P & B(a)P: 0.2 mg/kg coal charged PAH: 15 mg/kg coal charged
Coal Conversion	<i>Least</i> Chrysene: 1 µg/g burnt coal <i>Most</i> Naphthalene: 1500 µg/g burnt coal
Petroleum Refining	Naphthalene & derivatives: 85% of PAH in refinery 2-3 rings compounds: 94% of PAH in refinery 5 rings: ~ 0.1% PAH in catalytic cracking unit PAH: 0.1 tpa (Canada) 11 tpa (Germany)

B(a)P: benzo(a)pyrene; B(e)P: benzo(e)pyrene

Carbon black plants; bitumen processing and wood preservation with creosotes are also sources of PAHs in ambient air. (Source: IPCS, 1998)

PAH emission sources and PAH emission rates into the environment have been reviewed in the Environmental Health Criteria monogram on PAHs by WHO's International Programme on Chemical Safety (IPCS, 1998). Some emissions data reported in the IPCS monogram are summarised in Tables 1 and 2. The processing of coal and petroleum products, power plants using fossil fuel, incineration, aluminium production, iron and steel production are major industrial processes which occur in Australia and are known to be sources of PAH emissions.

Table 2. PAH Emissions due to Incomplete Combustion from Industrial Processes.

Emissions Source	Typical Emissions/Profiles
Power Plants using fossil fuel	Nap, Phe & derivatives: 69 – 92% of PAHs emitted Nap: 31-25% of PAHs emitted B(a)P: 0.02 mg/kg coal burnt B(e)P: 0.03 µg/kg coal burnt B(a)P: 0.1 tpa (Germany) PAH: 0.1 tpa Norway PAH: 11 tpa Canada
Incinerators (refuse burning)	B(a)P: 0.001 tpa (Germany) PAH: 50 tpa (USA) PAH: 2.4 tpa (Canada)
Aluminium Production (vertical process)	B(a)P: 0.11 kg/t aluminium PAH: 4.4 kg/t aluminium 1000 tpa (USA) 930 tpa (Canada)
Iron & Steel Production	PAH: 34 tpa (Norway) PAH: 19 tpa (Canada)
Foundries	PAH: 1.3 tpa (Netherlands)
Sinter process	1.3 tpa (Netherlands)
Phosphorus Production	0.2 tpa (Netherlands)

Nap: naphthalene; Phe: phenanthrene; B(a)P: benzo(a)pyrene & B(e)P: benzo(e)pyrene (Source: IPCS, 1998)

2.2 Source Markers

Specific PAHs have been suggested as being indicative for certain processes that release PAHs into the environment. These PAHs are called source markers. PAH concentration profiles and ratios can be used to determine the contribution of different sources to PAH concentrations in air.

2.2.1 Source Profiles

Khalili *et al.*, (1995) determined the chemical composition (source fingerprints) of the major sources of airborne PAHs in the Chicago metropolitan area, from 1990 - 1992. They found that two and three ring PAHs were responsible for 98, 76, 92, 73 and 80% of the total concentration of the measured 20 PAHs from coke ovens, diesel engines, highway tunnels, petrol engines and wood combustion samples respectively (the results are in Table 3). Six ring PAHs such as indeno(1,2,3-c,d)pyrene and benzo(g,h,i)pyrene were mostly below the detection limit and were only detected in the highway tunnel, diesel and petrol engine samples.

Table 3. Source Distribution of Percentage PAHs to Total Mass (Khalili *et al.*, 1995)

PAH¹	Highway	Diesel	Petrol	Coke	Wood
------------------------	----------------	---------------	---------------	-------------	-------------

	Tunnel	Engines	Engines	Oven	Combustion
2-ring	76	8.7	55	89	11
3-ring	16	56	18	8.9	69
4-ring	4.3	10	12	0.97	6.6
5-ring	3.1	18	13	0.22	13
6-ring	0.38	5.2	0.053	0.014	Bdl
7-ring	Bdl	0.18 ²	0.082	Bdl	Bdl

¹ 2-ring: naphthalene;

3-ring: acenaphthene, acenaphthylene, fluorene, phenanthrene, anthracene, and retene;

4-ring: fluoranthene, pyrene, benz(a)anthracene, chrysene and triphenylene;

5-ring: cyclopenta(c,d)pyrene, benzo(b/k)fluoranthene, benzo(a/e)pyrene, and dibenzo(g,h,i)perylene;

6-ring: indeno(1,2,3-c,d)pyrene and benzo(g,h,i)pyrene;

7-ring: coronene

²Based on one measurement

Bdl: below detectable limits

The following PAHs have been suggested as PAH source markers (Harrison *et al.*, 1996):

1. Chrysene and benzo(k)fluoranthene are markers for coal combustion.
2. Benzo(g,h,i)pyrene, coronene and phenanthrene are markers for motor vehicle emissions.
3. Phenanthrene, fluoranthene and pyrene are associated with road salt particles (from salting roads during winter), which appear to be absorbing volatile PAH emissions from motor vehicles.
4. Pyrene, fluoranthene and phenanthrene are markers for incineration.
5. Oil combustion is associated with high loadings of the more volatile PAHs (fluorene, fluoranthene and pyrene), along with moderate loadings of the higher molecular mass compounds (benzo(b)fluoranthene and indeno(1,2,3-c,d)pyrene).

2.2.2 PAH Ratios

The binary ratio method for PAH source identification, involves comparing ratios between pairs of frequently found PAH compounds characteristic of different sources. Stationary source combustion emissions from the use of coal, oil and wood are low in coronene relative to benzo(a)pyrene, while mobile source combustion emissions from diesel and petroleum use are high in benzo(g,h,i)perylene and coronene relative to benzo(a)pyrene (Stenberg *et al.*, 1979). The ratio of these PAHs (Table 4) can be used to distinguish between traffic dominated PAH profiles and other sources (Brasser, 1980; Mainwaring and Stirling, 1981, cited in Hooper *et al.*, 1993).

Table 4. Binary Ratios for Traffic and Coal Sources

Source Type	B(a)P/Cor ^a	B(a)P/B(ghi)P ^b
Mobile Sources	<0.4 – 1.0	0.2 – 0.6
Stationary Sources	>1.7	>0.8

^aBenzo(a)pyrene/coronene concentration ratios

^bBenzo(a)pyrene/benzo(g,h,i)perylene concentration ratios

3. PAH Studies in Australian Cities (1990-1999)

Since 1990 there have been several studies on PAH levels in Australian cities. These studies involved the collection and chemical analysis of PAH samples in the air environment from various sites in the cities.

3.1 Summary of Studies Conducted in each State

A summary of the PAH studies done in Australian cities from 1990 to present is shown in Table 5. The measurement sites and periods of study are included in the table.

Table 5. PAH Studies in Australian Cities (1990-1999)

City	Sites	Study Period	References
Brisbane ^a	Nathan, Woolloongabba, Fortitude Valley, Mount Gravatt, Dutton Park, Redbank & Graceville	July 1994 - June 1995	Muller, J.F. <i>et al.</i> , 1998; 1996a; 1995a,b; and Muller, J.F., 1997
Perth ^b	Caversham, Swanbourne & Duncraig	April 1994 - July 1995	Gras, 1996
Northern Territory ^c	Darwin Jabiru East	December 1994 – December 1996 December 1994 – July 1997	Vanderzalm <i>et al.</i> , 1998
Launceston ^d	Ti Tree, Newnham, East Launceston, Glen Dhu & Newstead	July 1991 -September 1993	Expert Working Party, 1996
Melbourne ^e	Alphington & Footscray Debney's Park-Flemington Collingwood	May 1990 - June 1990 November 1990 - November 1991 January 1993 – December 1993	Gras <i>et al.</i> , 1992 VicRoads/EPA, 1991 Panther <i>et al.</i> , 1999
Canberra ^f	Civic, Woden & Gowrie	September 1996 - March 1997	Fox, I., 1999
NSW ^g (Industry Sites)	Coalcliff, Corrimal-Railway St., Corrimal High School, Mayfield, Waratah, Warrawong-Wattle Rd. & Warrawong-Scouts Hall	January 1996 - December 1997	NSW EPA, 1996; NSW EPA, 1997

^aPAHs were collected from 7 urban sites within a radius of 15 km of Brisbane. Several PAHs were identified in the samples.

^bPAHs were measured at 3 sites in the Perth metropolitan area during the Perth Haze Study. No PAH monitoring has been undertaken in Perth since 1995.

^cPAHs were measured at an urban site, Darwin, and a rural site, Jabiru East, in the Northern Territory, only data for benzo(a)pyrene was explicitly reported.

^dPAHs were measured at 5 urban sites as part of a comprehensive air pollution study in Launceston and the Upper Tamar Valley. Sixteen PAHs were determined but only data for benzo(a)pyrene was reported.

^eThere were three PAH studies which involved Melbourne suburbs: 1)The Melbourne Aerosol Study (MAS), 2)VICRoads/EPA study at Debney's Park in Flemington 3)Asian/Australian cities study. All the sites reported here were urban sites.

^fPAH samples were collected from 3 urban sites in Canberra, a formal report on this data has not been written, hence only the results and analytical methods were presented in this report.

^gCurrent PAH ambient data from the NSW EPA air quality monitoring network were not available. Only industry self-monitoring data, collected under NSW EPA discharge licence conditions, were presented in this report.

3.2 PAH Compounds Identified

The types of PAH compounds identified in Australian cities from 1990 to present, are listed in Table 6. The number of times the concentration of any PAH has been reported, is represented by the total number of “X” entries. PAH studies in which concentrations were not reported, are represented by “M” entries in the table.

About 23 PAHs have been studied and their concentrations reported in the eight Australian studies and the NSW industrial self-monitoring results. Data for benzo(a)pyrene only were reported in two of the studies (Northern Territory and Tasmania).

The most studied PAHs in Australia were benz(a)anthracene, benzo(a)pyrene, benzo(b)fluoranthene, benzo(g,h,i)perylene, benzo(k)fluoranthene, chrysene, dibenz(a,h)anthracene, fluoranthene, phenanthrene and pyrene—their concentrations have been reported in at least six studies. Benzo(a)pyrene was the most reported PAH, its concentration was reported in all the studies.

Table 6. Types of PAHs Identified in Australian Cities

PAH	Total	Brisbane ^a	Perth ^b	NT ^c	Launc ^d	Melbourne			Canberra ^h	NSW ⁱ
						MAS ^e	DP ^f	Colling ^g		
Acenaphthene (Ace)	4	X	X	M	M			X		X
Acenaphthylene (Acy)	4	X	X	M	M			X		X
Anthanthrene (Anh)	1			M				X		
Anthracene (Ant)	6	X	X	M	M	X	X	X		X
Anthracene, 2-methyl (2M-Ant)	1	X								
Benzo(a)anthracene (B(a)A)	7	X	X	M	M	X	X	X	X	X
Benzo(a)pyrene (B(a)P)	9	X	X	X	X	X	X	X	X	X
Benzo(b)fluoranthene (B(b)F)	6	X	X	M	M		X	X	X	X
Benzo(e)pyrene (B(e)P)	4	X	X	M		X		X		
Benzo(g,h,i)perylene (B(g,h,i)P)	6	X	X	M	M		X	X	X	X
Benzo(k)fluoranthene (B(k)F)	6	X	X	M	M		X	X	X	X
Chrysene (Chr)	6	X	X	M	M	X	X	X		X
Coronene (Cor)	3	X		M		X		X		
Dibenz(a,h)anthracene (DB(a,h)A)	6	X	X	M	M		X	X	X	X
Fluoranthene (Fla)	6	X	X	M	M	X	X	X		X
Fluorene (Flu)	4	X	X	M	M			X		X
Indeno(1,2,3-c,d)pyrene (I(c,d)P)	5	X	X	M	M		X	X		X
Naphthalene	4	X	X	M	M			X		X
Naphthalene, 2-methyl (2M-Nap)	2	X	X							
Perylene (Per)	4	X	X	M		X		X		
Phenanthrene (Phe)	6	X	X	M	M	X	X	X		X
Pyrene (Pyr)	7	X	X	M	M	X	X	X	X	X

Total: number of studies reporting the concentration of the PAH compound

"X": Data reported for compound

"M": Compound studied, but concentration not reported

^aBrisbane (Muller, J.F. et al., 1998, 1996a, 1995a,b)

^bPerth (Gras, 1996)

^cNorthern Territory (Vanderzalm et al., 1998)

^dLaunceston (Expert Working Party, 1996)

^eMelbourne Aerosol Study (Gras et al., 1992)

^fDebney's Park at Flemington (VicRoads/EPA, 1991)

^gCollingwood (Panther et al., 1999)

^hCanberra (Ian Fox, 1999)

ⁱIndustrial self-monitoring data collected under conditions of NSW EPA discharge licences (NSW EPA, 1996; 1997)

4. Comparability of Sampling and Analytical Methods

Ambient PAH monitoring involves field collection of airborne particulate matter onto sorbents (**sampling**) followed by laboratory **chemical analysis** of the samples. The chemical analysis procedure involves sample preparation, including **extraction** from the collection media and **clean up** to remove any interfering compounds, and finally **instrumental analysis** to identify and quantify the PAHs. Several different methods have been used in Australia for PAH determination in ambient air. These sampling and analytical methodologies are summarised in Table 7 and compared in the following sections. Analytical methods for PAHs seem to be well established, but there are inconsistencies in sampling duration, sample filter types, sampling rates and even the phase of the samples collected.

4.1 Sampling Methods

Physical forms of PAHs determine their transport, degradation, deposition and their subsequent fates and behaviour in the air environment. The efficiency of PAH collection is dictated by its physical state, ie, whether it exists entirely in the solid phase or partly in the vapour phase. PAHs are characterised by high melting- and boiling- points and very low solubilities in water. Most PAHs have low vapour pressures at ambient conditions.

PAH sampling in Australia has normally been achieved by drawing large volumes of ambient air through filter paper located on a mass flow controlled (1.1 m³/min) high volume sampler (Hi-vol). Airborne particles are collected for 24 hours or longer onto glass-fibre filters. Other filter media that can be used for sampling include quartz fibres, polytetrafluoroethylene (PTFE) and PTFE-coated glass-fibre. The glass-fibre filter has good mechanical strength and is not expensive hence it is the popular choice for airborne particulate matter sampling (Sawicki, E., 1962).

During PAH sampling non-volatile PAHs (vapour pressure less than 10⁻⁸ mm Hg) may be trapped on the filter but post-collection volatilisation can cause the loss of PAHs from the filter. For example, PAHs with five or more rings are almost exclusively absorbed on particulate matter collected on the filter, but the lower-molecular-mass PAHs are not fully retained, due to their volatility (Yamasaki *et al.*, 1982). Thus the collection of airborne particulate samples on filters only could grossly underestimate ambient PAH concentrations, especially for those compounds with molecular masses less than 252 g/mole (Thrane and Mikalsen, 1981).

Several attempts have been made to collect volatile PAH fractions—these include impregnating the filter medium, using a back-up filter or a solid adsorbent behind the filter (Lodge, 1988). Employing appropriate solid adsorbents downstream of the filter appears to be the most practical vapour collection technique. Vapour-phase PAHs are normally trapped onto plugs of polyurethane foam (PUF) located behind the particulate filter (see for example Hawthorne *et al.*, 1992). Other adsorbents that have been successfully used to trap PAHs include Amberlite XAD-2 (a styrene-divinylbenzene polymer resin), Porapak PS and Tenax GC.¹

¹ The use of propriety names here does not mean endorsement of these brands.

Table 7. Sampling and Analytical Methods used for PAH determination in Australia

Parameter	Brisbane ^a	Perth ^b	NT ^c	Launceston ^d	Melbourne	Canberra ^h	NSW ⁱ
SAMPLING							
Sampler type	Low-Vol.	Low-Vol.	Hi-vol	Hi-vol	Hi-vol	Hi-vol	Hi-vol
Particle size	TSP	FPM; PM10	TSP	TSP; PM10	TSP	TSP; PM10	TSP
Collection frequency	Site Rotation (week days)	6-day cycle; LVD<40km	12-day cycle	Daily (site rotation)	Monthly	6-day cycle	6-day cycle
Collection duration/ (Volume)	2-9 days (200-1000 m ³)	8 – 56 h; 12 h (50 m ³ ; 700 m ³)	24 h (1630 m ³)	24 h	24 h (1700 m ³)	24 h (1462 m ³)	24 h
Particulate filter	Glass-fibre	Quartz	Glass-fibre	Glass-fibre	PTFE-glass-fibre	Glass-fibre	Glass-fibre
Vapour absorbent	XAD-2	None	None	None	None	None	None
EXTRACTION							
Apparatus	Soxhlet	Ultrasonic	Ultrasonic	Ultrasonic	Soxhlet	1)Ultrasonic 2)SFE	
Time	10 h	30 min			2 h	1)30 min 2) 20 min	
Solvent	Acetone-n-hexane	Hexane-acetone-DCM		DCM	Methylene chloride	1)DCM-acetone 2)CO2	
CLEAN-UP		None	None	None	None	None	
Column	Silica gel-LC				Silica gel	1)NH2/C18 2)ODS	
Eluent	DCM-cyclohexane				Aceto-nitrile	1)Acetonitrile 2) THF-Acetonitrile	
Final Volume (µl)	300				1x10 ⁶	500	
ANALYSIS							
Instrument (Column)	GC	GC	HPLC	GC	HPLC	HPLC (C18)	GC
Detection	MS	MS	UV/FL	MS	UV/FL	Fluorescence	MS
Calibration Standards	Internal d-PAHs	Internal d-PAHs			Internal	External	
Detection (ng/m ³)	0.026-0.052						0.012 –0.096

DCM: dichloromethane

THF: tetrahydrofuran

ODS: OctaDeca Silica gel column

d-PAHs: deuterated PAHs

^aBrisbane (Muller, J.F. *et al.*, 1998, 1996a, 1995a,b)

^bPerth (Gras, 1996)

^cNorthern Territory (Vanderzalm *et al.*, 1998)

^dLaunceston (Expert Working Party, 1996)

^eMelbourne Aerosol Study (Gras *et al.*, 1992)

^fDebney's Park at Flemington (VicRoads/EPA, 1991)

^gCollingwood (Panther *et al.*, 1999)

^hCanberra (Fox, I., 1999)

ⁱIndustrial self-monitoring data collected under conditions of NSW EPA discharge licences (NSW EPA, 1996; 1997)

PAHs that occur mostly in the vapour phase are thought to be of lesser toxicological interest (Smith and Harrison, 1998). However this is not entirely true since benz(a)anthracene, classified as a possible human carcinogen, occurs almost entirely in the vapour phase (Baek *et al.*, 1992; IARC, 1987). The Brisbane study was the only one which involved the collection of vapour phase PAHs in addition to particulate phase PAHs: the other Australian studies measured only particulate phase PAHs. An Amberlite XAD-2 resin solid adsorbent, placed behind the particulate filter, was used to collect the vapour phase PAHs. A special sampler was constructed to hold the solid adsorbent and filter (Muller, J.F. *et al.*, 1995c).

In most of the Australian studies, samples were collected over a 24 hour period. However, very long sampling times were used during the Brisbane study (2 – 9 days), which could be attributed to the slower sampling rates of the sampler used, a low volume (Lo-vol) type.

In the Perth study and the Melbourne Aerosol Study (MAS) samples could be collected over shorter durations (12h or less) since they were only collected during periods of low visibility (LVD < 40km), when pollutant concentrations were expected to be high.

The frequency of collection for most of the studies was based on a one-day-in-six cycle. This is a very economical method of sampling if daily sampling is not affordable, and avoids any bias towards weekday sampling. In the Launceston study samples were collected daily, but on a site rotation cycle.

Most of the Australian studies determined PAH concentrations from total suspended particles (TSP). However, some studies (Perth and Canberra) used size-selective inlets to collect particulate matter with aerodynamic diameters of 10 µm or less (PM10). The Perth study and the Melbourne study (MAS) even collected fine particle mass (FPM).

Potential sources of error associated with PAH collection are post-collection volatilisation and chemical reaction (artefact formation), which would be manifested in:

- Degradation of collected PAHs by other pollutants/temperature/solar radiation.
- Breakthrough of PAHs from adsorbent.
- Adsorption of vapour phase PAHs onto filters or onto particles on filters (blow on).
- Volatilisation of PAHs from filter-retained particles (blow off).

Muller, J.F. *et al.* (1996b) have examined artefact formation that occur during particle and vapour phase sampling of PAHs using filters and adsorbents. They claim that the occurrence

of sampling artefacts can result in the overestimation or underestimation of the true vapour phase and true solid phase PAH concentrations.

Volatilisation of PAHs collected on filters is caused by large pressure drops across the filter and can be reduced by using short sampling times or slower flow rates at the expense of analytical sensitivity (Zhang and McMurry, 1991). The extent of artefact formation, caused by chemical reaction with ambient air pollutants such as NO₂, O₃ and SO₂, can be reduced by using inert filters such as PTFE (Grosjean *et al.*, 1983). However, this could result in a large pressure drop that would increase PAH volatilisation.

The use of annular diffusion denuders with back-up filters appears to have the potential to reduce artefact formation during PAH sampling (Eatough *et al.*, 1993). However, the denuder coating limits the success of this method. Presently available coatings can only be used at slow sample flow rates.

In principle, short sampling times and slow flow rates would reduce sampling errors. In practice, sampling is normally done for a duration of 24 hours, and a minimum total sample volume of 325 m³ is required to concentrate PAHs to levels above the analytical limit of detection and avoid sample breakthrough. Only the Brisbane study collected most of the samples for more than 24 hours. Hi-vols were used in a majority of the Australian studies. Although sample volumes ranged from 24 m³ to 1700 m³, most of the sampling volumes were above 600 m³.

It is very difficult to compare PAH data, because of the different methods used to collect the samples. Methods, which require long sampling times, will enhance artefact formation by increasing PAH contact times with other air pollutants. Samplers operating at high flow rates increase volatilisation, hence loss of the lower molecular weight PAHs from the samples, if solid adsorbents are not in place to collect the vapour phase PAHs.

4.2 Analytical Methods

More standardised methods are available for chemical analyses of PAHs, using state-of-the-art instruments such as the gas chromatograph/mass spectrometer (GC/MS) and high performance liquid chromatograph (HPLC). The available standard methods for PAH determination in air include the US EPA Compendium Method TO-13 (US EPA, 1989), the revised method TO-13A (US EPA 1999) and the International Organisation for Standards method 12884 (ISO, 1997).

4.2.1 Extraction

The PAHs collected onto the filters or adsorbed onto solid adsorbents are extracted with appropriate solvents and the solvent volume reduced prior to instrumental analysis. Three different methods have been used for PAH extraction in the Australian studies: Soxhlet extraction, ultrasonic extraction and supercritical fluid extraction.

Traditionally PAHs are extracted from various matrices by Soxhlet extraction. The filter or solid adsorbent is placed in a Soxhlet tube and about 300 ml of an appropriate solvent such as acetone, n-hexane, toluene, benzene or dichloromethane (or combinations of the solvents) are added. The mixture is then refluxed for 10 to 24 hours. The extracts from the samples are next concentrated to a volume of approximately 1mL, using a rotary evaporator or a

Kuderna-Danish evaporator. The Brisbane study used the Soxhlet method for extracting PAHs from ambient particles. The Melbourne Debney's Park Study reported that the US EPA method 8310 (US EPA, 1990) was used for PAH analysis—this method requires Soxhlet extraction of the PAHs.

The Soxhlet method is a very efficient method for extracting PAHs and it is the preferred procedure in the US EPA method TO-13/A and the ISO standard method 12884 for PAH determination. These standard methods require the volume of solvents used for extraction to be reduced using a Kuderna-Danish (KD) solvent evaporating apparatus (diagrams of the apparatus used for sample preparation are in Appendix D). Unfortunately the Soxhlet extraction method suffers from the disadvantage of requiring extremely long extraction times and involves the use of hazardous solvents.

Several Australian studies reported the use of the ultrasonic extraction method. This appears to be an inexpensive and fast method for sample extraction. The Canberra study used the US EPA Method 3550A (revision 1) procedure for extracting particulate phase PAHs from filters (US EPA, 1990). It involved extraction with 100 mL of a 50/50 mixture of acetone and dichloromethane in an ultrasonic bath for 30 minutes. This was followed by concentration in a Kuderna-Danish (KD) apparatus to reduce the volume to below 200 μ L. This method of extraction was later abandoned for the supercritical fluid extraction (SFE) method.

The Canberra study found the ultrasonic extraction method yielded high recoveries when applied to a NIST standard urban dust sample (SRM 1649). However, inconsistent results were obtained when the ultrasonic method was used for filters spiked with PAH standards. It appears that the method, which involves the ultrasonic agitation of particulates in polar solvents, could be less efficient than the Soxhlet method. The ultrasonic method could be well suited for samples with higher PAH concentrations, such as those obtained from sediments and may not be suitable for airborne particulate samples. None of the other Australian studies, which used the ultrasonic extraction method, reported on the PAH extraction efficiencies.

Supercritical fluid extraction (SFE) is being used as a rapid alternative to conventional solvent extraction from polyurethane foam absorbents (Hawthorne *et al.*, 1989). The high diffusivity and low density/viscosity of supercritical fluids allows them to rapidly penetrate a sample matrix and effect a more rapid extraction of the PAHs. Supercritical carbon dioxide has been used for the extraction of PAHs in urban dust samples (Langenfeld *et al.*, 1993; Janda *et al.*, 1993) and diesel exhaust particulates (Kelly *et al.* 1992). Extraction time is about 90 minutes and little waste is produced. The use of a 10% methanol modifier increases PAH recoveries considerably (Lewis *et al.*, 1994; Monserrate and Olesik, 1997).

The Canberra study was the only Australian study that reported the use of SFE for extracting PAHs. A Hewlett Packard SFE 780T apparatus was used for extracting cut PAH-loaded filters, placed in SFE thimble tubes at 80°C and 121-335 atmospheres, using supercritical carbon dioxide. Greater than 60% yields were obtained from spiked filters. Extraction of a NIST Diesel Particulate sample (SRM 1650) yielded excellent recovery results.

4.2.2 Sample Clean-up

After extraction, samples have to be purified (cleaned) to remove unwanted contaminants, which could interfere with subsequent analytical procedures. Extracts from SFE processes,

for example, can contain many hundreds of aliphatic and polar compounds in addition to the PAHs.

Extracted samples are usually purified by column chromatography, to eliminate interferences from both polar and non-polar compounds. Alumina and silica gel have been widely used as column sorbents. Sephadex LH-20, a hydrophobic sorbent, is also suitable for isolating PAHs from non-aromatic and non-polar compounds. Chromatography on silica gel and Sephadex is often combined (Jacob and Grimmer, 1979). The detector being used for analysis would dictate the choice of solvent for eluting the PAHs from the LC column.

The Brisbane study used 2 g of activated silica gel in a 0.8 cm ID column fitted with a PTFE tap. Samples were applied quantitatively to the columns and eluted with three 10 mL mixtures of dichloromethane/cyclohexane in different proportions. Combined eluants were reduced to volumes of 50 μ L under a gentle stream of ultra-high-purity nitrogen gas.

In the Canberra study, an NH₂-C18 column was used to clean up samples extracted by ultrasonic agitation. Acetonitrile was used to elute the PAHs from the clean-up column. Samples extracted by supercritical CO₂ were cleaned on a Hewlett Packard OctaDeca Silica gel (ODS) column, using a 50/50 mixture of tetrahydrofuran (THF)/acetonitrile as the eluting solvent.

Most of the Australian studies presented in Table 7 did not report any clean-up procedures for the extracted PAH samples prior to instrumental analysis. Complex sample matrices require purification, but relatively clean matrices do not need to be cleaned; however, this was not reported as the reason for the lack of clean-up procedures.

4.2.3 Instrumental Analysis

The literature shows that analysis by HPLC, using fluorescence or UV-visible detection, or GC, with MS or flame ionisation detection (FID), are the most common methods for identifying and quantifying PAH extracts from air samples. The detection limits of these instruments for PAHs, as reported in some studies and cited in IPCS monogram (IPCS, 1998), are in Table 8. Most of these analytical instruments have been used in the studies done in Australian cities.

Table 8. PAH Limits of detection for some Chromatography Methods

Sample	Instrument	Limit of detection	Reference
Ambient Air	HPLC/FL	0.01-0.7 ng/m ³	Keller & Bidleman, 1984
Ambient Air	HPLC/UV + FL	0.01-0.3 ng/m ³	Greenberg <i>et al.</i> , 1985
Incinerator emissions	GC/FID	10 ng/m ³	Colmsjo <i>et al.</i> , 1986
Indoor Air	HPLC/FL	0.02-0.12 ng/m ³	Daisey & Gundel, 1993

FL: fluorescence detection

FID: flame ionisation detection

Gas chromatography-mass spectrometry (GC/MS) and high performance liquid chromatography (HPLC), using UV-visible or fluorescence detection, are the two main types

of instrumental analysis that have been used in Australia to identify and quantify PAHs extracted from ambient air samples. Most of the techniques enabled separation and quantification of PAH in the nanogram per m³ (ng/m³) ambient concentration range. Detection limits reported by the Brisbane study, which used GC/MS for analysis, ranged from 0.026-0.052 ng/m³. An HPLC was used in the Canberra Study, and the range for the detection limits was 0.012–0.096 ng/m³. These reported detection limits are comparable to the literature values in Table 8.

There are several gas chromatography capillary columns available than can effect separation of PAH mixtures. The most common stationary phases used are the polysiloxanes: SE-54, SE-52, SE-30, OV101, OV-17 and Dexsil 300². Typically, GC columns suffer from “column-bleeding” at the high temperatures required for analysis of high molecular weight PAHs. Chemically bonded stationary phases are increasing being used since they can be rinsed to restore column performance and undergo little “column-bleeding”.

To increase GC sensitivity, splitless on-column injection is used for trace PAH species. The FIDs show excellent linearity, sensitivity and reliability for quantifying the species. However, since FIDs are non-selective, another method such as GC/MS or HPLC must be used to identify the peaks. Further, since GC retention times are used for peak identification, the samples must be “cleaned” to avoid interference from unknown species.

Mass spectrometers are powerful tools for identifying compounds, especially with the availability of large reference library spectra such as the NIST library (NIST, 1992). The sensitivity of the GC/MS can be increased if the mass spectrometer is operating in a select ion monitoring (SIM) mode, where it scans only selected ion masses.

The HPLC packing material most suitable for separating PAHs consists of silica particles chemically bonded to C18 hydrocarbon chains. The 25-cm columns are packed with 5- μ m particles and the mobile phase is a mixture of acetonitrile and water or methanol and water.

Compared to capillary GC, HPLC is generally less suitable for separating samples containing complex PAH mixtures. However, the UV or fluorescence detectors used in HPLC are highly specific and sensitive. The detection limit of the fluorescence detector is an order of magnitude greater than the UV detector. Another advantage of the fluorescence detector is that it can determine PAHs in the presence of other non-fluorescent compounds. HPLC can resolve the peaks of various isomers such as chrysene & triphenylene or benzo(b)fluoranthene and benzo(k)fluoranthene, which cannot be adequately resolved by capillary GC.

Some of the Australian studies reported PAH concentrations for the 16 parent PAH species specified in the US EPA priority list for PAHs (US EPA, 1989). These 16 species, present in the NIST Standard Reference Material SRM-1647, are normally used for calibrating the analytical instruments.

The internal standard method is the accepted calibration method, and involves the use of deuterated PAH species with molecular masses and retention times which are close to a cross section of the native PAHs. Addition of these surrogate PAH species to the sample before extraction provides a means of measuring extraction efficiencies. It is assumed that the

² The use of propriety names here does not mean endorsement of these brands.

percent recovery of a native PAH after extraction would be the same as that of its surrogate. Thus the percent recovery of the native PAH can be determined from the surrogate recovery.

4.2.4 Electrophoresis Methods

Capillary electrophoresis (CE) methods have emerged as important separation tools in chemical analysis and have the potential to rival traditional separation techniques such as GC and HPLC. These techniques involve the use of electroosmotic flow (EOF), an electrically induced force that moves a mobile phase (electrophoretic buffer) through a packed bed column, to effect separation of different electrical species on the column. There have been no reports on the use of this method for chemical analysis of airborne PAHs in Australian cities.

A recent review of the international literature by Dabek-Zlotorzynska (1997), of capillary electrophoresis applications to environmental samples from 1994 to 1997, found that although several PAH samples had been analysed by CE methods during that period, only one study had involved samples from ambient air (Dabek-Zlotorzynska and Lai, 1996).

The capillary electrophoresis method that has been successfully applied to ambient PAH samples is micellar electrokinetic capillary chromatography (MEKC). In this method, electrically neutral PAHs are given a charge by the addition of an ionic surfactant to a buffer containing the PAHs. The surfactants form micelles that react with the PAHs. Separation of the PAHs is based on their hydrophobic interaction with the micelles—the stronger the interaction, the longer they take to migrate through the column with the micelle. Dabek-Zlotorzynska and Lai (1996) used sodium taurodeoxycholate as a surfactant for the analysis of the 16 US EPA priority PAHs; however, they were unable to separate indeno(1,2,3-c,d)pyrene and benzo(g,h,i)perylene. Detection was by UV light at 254 nm wavelength but no detection limits were reported.

Another CE method being used for PAH analysis is capillary electrochromatography (CEC). It is a combination of liquid chromatography (LC) and capillary electrophoresis. In CEC, the capillary is packed with a stationary phase similar to those used in LC. When an electric field is applied, the EOF moves the mobile phase through the packed column resulting in separation due to partition between the stationary and mobile phases. The separation is efficient and requires short analysis times. The CEC method has been used to separate the 16 priority PAHs, from a standard sample, on a fused-silica capillary packed with octadecylsilica particles (Yan *et al.*, 1995).

4.2.5 Continuous PAH Analysers

The photoelectric aerosol sensor (PAS) is an instrument used for real-time measurement of total particle-bound PAH concentrations in air. This instrument works on the principle of photo-ionisation of the PAHs using a UV excimer lamp. The electrons emitted when the PAHs absorb the narrow band high intensity UV radiation are measured with an aerosol electrometer, the output signal of which is proportional to the total PAH concentration (Agnesod *et al.*, 1996). The PAS sensitivity is in the ng/m^3 range.

During the Perth Haze Study two Ulrich Matter photoelectric monitors were used to provide real time total PAH concentrations (Gras, 1996). These instruments respond to a broad range of particle bound PAHs and produce a signal proportional to the combined concentrations of the suite of monitored PAHs. Although the instruments do not provide speciated PAH

concentrations, they could be useful tools for identifying ‘hot spots’ for measuring PAH concentrations by conventional methods.

4.3 Recommended Methods for Measuring PAHs

It will be difficult to compare PAH levels between different jurisdictions because of the varying methods used to determine them. In the absence of standard or systematic PAH measurement methods across Australia, this report will present recommendations for PAH sampling and measurement.

4.3.1 Recommended Sampling Method

The measurement of both particulate and vapour phase PAHs in the air environment should conform to current international standard methods used for PAH determination in air (US EPA, 1989; US EPA 1999; ISO, 1997). It is recommended that vapour phase PAHs be collected in Australian cities, in addition to particulates. However, if it can be shown that the vapour phase PAH fraction at a location is at a level that would not cause detrimental human health effects, then only particulate phase PAHs may need to be collected.

Figure 1. Modification of a PM10 filter head to Accommodate PUF Sorbent Sheets

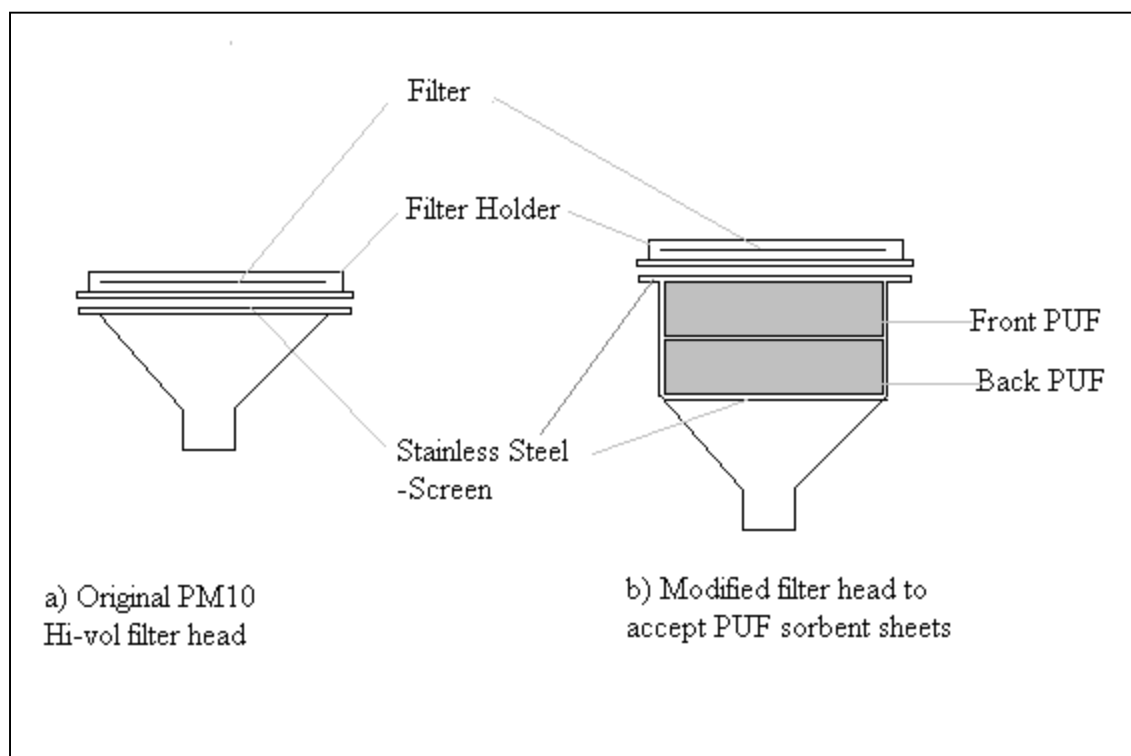

(Adapted from Hawthorne et al. (1992))

Most studies which measured both particulate and vapour phase PAHs used modified PM10 High volume (Hi-vol) samplers to collect the PAHs. The Hi-vols were originally designed to collect PM10 particles only onto filters (18cm x 23cm) for gravimetric measurements to determine particle loading. Sometimes the filter paper was cut into four quarters after sampling, with each quarter analysed differently for the different types of particulate air pollutants, such as lead. The remaining quarters were used as duplicate samples.

It should be possible to modify these Hi-vols to contain filter paper and solid adsorbents for collecting both particulate and vapour phase PAHs, as shown in Figure 1. The diagram in Figure 1 shows how a PM10 Hi-vol filter head was adapted to accommodate polyurethane foam (PUF) sorbent sheets (Hawthorne *et al.*, 1992). The filter head was extended by 10 cm, by welding a stainless steel sheet to the filter support screen. An additional stainless steel screen was added to support the two PUF sheets (18cm x 23cm x 5cm).

The US EPA Method TO-13 for PAH sampling and analysis describes a General Metal Works PS-1 Hi-vol sampler that can be used for dedicated PAH sampling (US EPA, 1989, 1999). The sampler utilises a 9-cm diameter filter and XAD-2 or PUF adsorbents in a glass cartridge holder. Schematics of the sampler and cartridges are shown in the diagram in Appendix C. This type of sampler collects total suspended particles (TSP) and does not utilise a size selective inlet to sample smaller size particles.

Table 9. Attributes of Solid Adsorbents used for PAH Sampling

	XAD-2	PUF
Benzo(a)pyrene collection efficiency	High	High
Benzo(a)pyrene storage capability	High	low
Volatile PAH collection efficiency	Higher	High
Volatile & Reactive PAH Retention efficiency	Higher	High
Field handling	Good	Better
Flow characteristics	Good	Better
Naphthalene recovery efficiency	High	low
Naphthalene blank	Low	Lower
Other hazardous air pollutants that can be collected		PCBs, dioxins & Pesticides

PUF and XAD-2 are the most common adsorbents used for vapour phase PAH collection, yet they have their inherent weaknesses and strengths (Table 9). For example, although most adsorbents have shown high collection efficiencies for benzo(a)pyrene, only XAD-2 has high collection efficiency for volatile PAHs such as naphthalene. PUF cartridges are easier to handle in the field and demonstrate superior flow characteristics during sampling. PUFs can also be used to collect and analyse for other hazardous air pollutants such as organochlorine pesticides and polychlorinated biphenyls.

Some environmental agencies recommend the use of both adsorbents, together, to address post-collection volatilisation problems associated with volatile and other reactive PAHs (LBS, 1995). It is recommended that XAD-2 be used sandwiched between two PUF plugs. Since XAD-2 can retain up to 99% naphthalene, the most volatile PAH, this configuration should be used with the filter paper for collecting PAHs in ambient air.

Recent research recommends the use of these adsorbents with PTFE filters—because of their inertness and low impurity levels (Hart and Pankow, 1990). However, there are inconsistencies between results of particulate samples collected on PTFE and on glass fibre (Baek *et al.*, 1991a).

Although there is a general bimodal distribution of exhaust particulates, the size distribution of PAH is unimodal, with its maximum at 1µm (Baek, 1988). Thus it is recommended that

the collection of PAH-loaded particles should be restricted to smaller size particles. Sampling should follow the procedures outlined in Australian Standard 3580.9.6 (Determination of Suspended Matter (PM10) Size Selective Inlet Method, 1990) for PM10 collection on a Hi-vol, which has been adapted for vapour collection.

In choosing a sampler the following parameters have to be considered:

- Use of a size selective inlet (SSI) to collect particles of aerodynamic diameter, preferably, 10µm or less.
- Choice of a flow rate that would result in PAHs collection on the filter paper at concentrations above the limit of detection of the analytical instrument after sample preparation. It should be noted that SSIs that use cyclones operate at only specific flow rates.
- Choice of a filter paper and solid adsorbent that can be cleaned before sampling. Cleaning should be done with solvents that would be used in the subsequent steps of sample preparation before analysis.
- Choice of sampling duration and frequency that would result in the collection of representative samples.
- Automation of the sampler to run at programmed times.
- Accurate determination of sample volume, which should be corrected to standard ambient conditions.

The configuration recommended for sampling is summarised in Table 10.

Table 10. Recommended Configuration for PAH sampling

Parameter	Recommended Apparatus	Notes
Sampler type	High volume	High flow rate
Particle size	PM10	To correspond with NEPM on airborne particles
Filter	Glass fibre/baked quartz/ PTFE	Cleaned before use
Solid absorbents	XAD-2 sandwiched between two PUF plugs or sheets	Placed after the filter and cleaned
Sampling duration	24 h	Correct sample volume to standard conditions
Sampling frequency	1-day-in-6 cycle	Daily if possible, but 1-day-in-12 at the least

4.3.2 Recommended Chemical Analysis Methods

It is recommended that the US EPA methods TO-13 & TO-13A, which are validated standard methods used for determining PAHs in ambient air, be adopted for chemical analyses of PAHs collected in Australian cities (US EPA, 1989, 1999). These methods can be used to determine up to nineteen PAHs in airborne particulate matter. Any other PAHs known to be indicators of major pollutant sources and/or carcinogenic and suspected to be present should also be determined by these methods.

The TO-13 methods require Soxhlet extraction, for 18 hours, of the filter and adsorbents (together) using methylene chloride (an ether/hexane mixture should be used for PUF

extraction). After extraction, the extract is dried over anhydrous sodium sulphate, then the solvent is exchanged with cyclohexane. The “solvent exchange” procedure involves concentrating the extract on a Kuderna-Danish evaporator (K-D) attached with a MacroSynder Column (see Appendix D), then adding 5mL of cyclohexane and concentrating to a volume of 1 mL.

A small silica gel column, topped with sodium sulphate, is used to clean the cyclohexane extract. The PAHs absorbed onto the column are eluted with pentane/methylene chloride and the fractions concentrated on the K-D apparatus to 1 mL. The concentrated fractions can be analysed by gas chromatography using flame ionisation detection or mass spectrometric detection. If analysis is to be done by HPLC (using UV-visible or fluorescence detection), the concentrated fractions must be “solvent exchanged” to acetonitrile. GC/MS analysis of PAHs is the analytical method recommended in the revised Compendium Method TO-13A (US EPA, 1999).

The use of supercritical fluid extraction (SFE) should be considered as an alternate method, to Soxhlet extraction, to shorten sample preparation time and avoid the use of several glassware and solvents, which could be sources of sample contamination. Due to the fact that several organic compounds would be extracted by the SFE, sample clean up on a silica gel column should be done.

The ultrasonic extraction method can be used if the PAH extraction efficiencies are reasonable and are reported.

The TO-13 method recommends the use of HPLC or GC/MS or GC/FID for identifying and quantifying the PAHs. Due to its sensitivity, selectivity and ability to analyse complex mixtures, GC/MS is the only recommended instrumental analysis method for PAHs by the revised TO-13A method. However, it would be recommended that HPLC or GC/FID continue to be used in Australian studies.

Most standard methods recommend the addition of surrogate standards to the sample, prior to extraction. The TO-13A method requires that these standards be added to the filter and sorbents in the field before sampling. The recovery of the surrogate standard is used to monitor PAH extraction efficiencies. Surrogate standards are chemically inert compounds not expected to be in environmental samples, and do not interfere with the analyses by co-eluting with the target PAHs. The following surrogates, which are commercially available, have been tested successfully on the corresponding analytical instruments (Table 11):

Table 11. Surrogate Standards for Determining Extraction Efficiencies

Surrogate Standard	Analytical Instrument
Dibromobiphenyl	GC/FID
Dibromobiphenyl	GC/MS
Decafluorobiphenyl	HPLC

Either external standards or internal standards can be used for calibration of the analytical instrument. Deuterated analogs of selected native PAHs recommended for use as internal standards are listed in Table 12. Unfortunately, deuterated analogs of the PAHs cannot be used for HPLC analysis, due to co-elution problems. However, 2-methyl chrysene or 6-methyl chrysene can be used as internal standards during HPLC analysis of PAHs.

Table 12. Deuterated –PAHs for Internal Standard Calibration

Perylene-d₁₂	Chrysene-d₁₂	Acenaphthene-d₁₀	Naphthalene-d₈	Phenanthrene-d₁₀
Benzo(a)pyrene	Benz(a)anthracene	Acenaphthene	Naphthalene	Anthracene
Benzo(k)fluoranthene	Chrysene	Acenaphthylene		Fluoranthene
Benzo(g,h,i)perylene		Fluorene		Phenanthrene
Dibenz(a,h)anthracene				
Indeno(1,2,3-cd)pyrene				

In addition, the analysis of several field blanks and duplicate samples are required for quality assurance purposes. Other procedures that should be enforced include cleaning of the filters and solid substrates before sampling; the same procedure used for sample extraction should be used for cleaning.

Selected samples should be analysed at several laboratories to investigate the presence of any bias in the analytical results.

Finally, the samples should be handled and stored in the absence of ambient UV light and heat (since PAHs are known to be photochemically labile and reactive). All PAH samples and standards should be treated as potential carcinogens and must be handled with care.

5. PAH Identification and Concentrations in Australia

The average concentrations and range of concentrations for speciated PAHs determined in Australian cities, from 1990 to the present, are summarised in Table 13. The table also includes the number of samples collected, the period of collection, the total PAH concentration (expressed as the sum of individual PAH concentrations) and the number of PAHs studied.

Table 13. Average Concentrations (ng/m³) of Ambient PAH (and range; max-min) measured in Australian Cities

PAH	Brisbane ^a		Perth ^b	NT ^c	Launce ^d	Melbourne		Canberra ^g	NSW ^h
	DP ^e	Colling ^f							
Number of Samples	30		62	121	N/A	12	12	42	708
Averaging Period	2-9 days		8-56 h	24 h	24 h	24 h	24 h	24 h	24 h
Fraction analyzed	Vap. Part.	Part.	Part.	Part.	Part.	Part.	Part.	Part.	Part.
Av. Total PAH (ΣPAHs) ⁱ	217	5.38	18.6	1.85	N/A	1.90	6.43	0.360	9.0
Number of PAHs that ΣPAHs is based	21	21	19	20		12	20	7	16
Acenaphthene (Ace)	5.86 (25.0-0.60)	Bdl	0.030 (0.198-bdl)				1.48 (1.59-bdl)		0.6 (1.0-0.1)
Acenaphthylene (Acy)	10.9 (70.0-0.62)	0.03 (0.12-bdl)	0.081 (0.525-bdl)				0.17 (5.56-bdl)		3.3 (36.0-0.10)
Anthanthrene (Anh)							0.093 (0.11-bdl)		
Anthracene (Ant)	1.60 (8.7-0.15)	0.04 (0.24-bdl)	0.035 (0.44-bdl)			0.003 (0.06-bdl)	0.05 (0.09-0.02)		0.2 (3.0-bdl)
Anthracene, 2-methyl (2M-Ant)	4.23 (16.0-0.37)	0.12 (0.58- Bdl)							
Benz(a)anthracene (B(a)A)	0.09 (0.34-0.01)	0.21 (1.43-0.01)	0.715 (8.73- Bdl)			0.09 (0.70-0.01)	0.17 (0.43-0.01)	0.017 (0.11-0.011)	1.1 (15.3- Bdl)
Benzo(a)pyrene (B(a)P)	0.03 (0.18- Bdl)	0.34 (1.95-0.01)	1.88 (19.7- Bdl)	0.05 (>0.7- Bdl)	1.77 (34.3- Bdl)	0.1 (1.43- Bdl)	0.17 (0.83-0.02)	0.046 (0.15-0.004)	1.4 (14.6- Bdl)
Benzo(b)fluoranthene (B(b)F)	0.06 ^j (0.15-0.01)	0.55 ^j (2.31-0.08)	2.15 (18.7- Bdl)			0.21 (1.34-0.01)	0.18 (0.55-0.04)	0.045 (0.18-0.003)	2.0 (22.2- Bdl)
Benzo(e)pyrene (B(e)P)	0.03 (0.16- Bdl)	0.35 (2.11-0.04)	1.26 (10.8- Bdl)				0.53 (0.98- Bdl)		

PAH	Brisbane ^a		Perth ^b	NT ^c	Launce ^d	Melbourne		Canberra ^g	NSW ^h
	DP ^e	Colling ^f							
Benzo(g,h,i)perylene (B(g,h,i)P)	Bdl (0.01- Bdl)	1.39 (6.6-0.09)	3.18 (38.7-0.009)			0.59 (4.26-0.03)	0.86 (3.38-0.11)	0.172 (0.58-0.007)	1.3 (16.3- Bdl)
Benzo(k)fluoranthene (B(k)F)	0.02 (0.06- Bdl)	0.57 (3.04-0.03)	1.68 (16.0- Bdl)			0.10 (0.70- Bdl)	0.069 (0.19- 0.003)	0.045 (0.081- 0.003)	1.4 (16.4- Bdl)
Chrysene (Chr)	0.26 ^k (0.86-0.02)	0.43 ^k (2.19-0.02)	0.801 (9.79- Bdl)			0.13 (0.65-0.01)	0.22 (0.47-0.01)		1.2 (14.6- Bdl)
Coronene (Cor)	0.11 (0.54- Bdl)	0.27 (0.54-0.03)					0.62 (2.72- Bdl)		
Dibenz(a,h)anthracene (DB(a,h)A)	0.01 (0.03- Bdl)	0.02 (0.04-0.01)	0.124 (0.84- Bdl)			0.06 (0.72- Bdl)	0.67 (2.4-0.08)	0.040 (0.55-0.01)	0.5 (6.9- Bdl)
Fluoranthene (Fla)	2.69 (9.7-0.55)	0.24 (1.45-0.02)	0.181 (1.45- Bdl)			0.09 (0.53-0.01)	0.15 (0.52- Bdl)		0.9 (11.5- Bdl)
Fluorene (Flu)	11.4 (70-1.2)	0.04 (0.28- Bdl)	0.117 (0.669- Bdl)				Bdl		0.8 (1.0-0.1)
Indeno(1,2,3-c,d)pyrene (I(c,d)P)	Bdl	0.83 (4.3-0.08)	1.58 (14.4-0.01)			0.28 (1.61-0.01)	0.41 (1.8-0.07)		1.2 (13.6- Bdl)
Naphthalene	74.8 150-40)	Bdl	1.743 (8.76- Bdl)				0.45 (1.0-0.02)		0.7 (1.0-0.1)
Naphthalene, 2-methyl (2M-Nap)	113 (400-30)	Bdl	1.94 (16.0- Bdl)						
Perylene (Per)	Bdl	0.06 (0.31- Bdl)	0.315 (3.12- Bdl)				0.078 (0.42- Bdl)		
Phenanthrene (Phe)	19.8 (59-4.0)	0.52 (9.0-0.03)	0.246 (1.17- Bdl)			0.05 (0.22- Bdl)	0.11 (0.26- Bdl)		0.5 (3.0- Bdl)
Pyrene (Pyr)	4.36 (92-0.71)	0.41 (2.34-0.04)	0.241 (1.65- Bdl)			0.13 (0.74-0.01)	0.17 (0.48-0.01)	0.037 (0.15-0.01)	1.1 (20- Bdl)

^aBrisbane data is presented separately for particulate bound (Part.) and vapour phase (Vap.) PAHs (Muller, J.F. et al., 1998, 1996a, 1995a,b & Muller, J.F., 1997)

^bPerth (Gras, 1996)

^cNorthern Territory (Vanderzalm et al., 1998)

^dLaunceston (Expert Working Party, 1996)

^eDebney's Park at Flemington (VicRoads/EPA, 1991)

^fCollingwood (Panther et al., 1999)

^gCanberra (Fox, I., 1999)

^hIndustrial self-monitoring data collected under conditions of NSW EPA discharge licences (NSW EPA, 1996; 1997)

ⁱΣPAHs: sum of individual PAH concentrations

^jReported as the sum of B(b)F & B(k)F, in some of the samples

^kReported as the sum of Chrysene and Triphenylene

Bdl: below detectable limits

N/A: Not available

Vapour phase and particulate phase PAH concentrations are presented separately for Brisbane. Data for the other studies represent only particulate phase PAH concentrations. The limits of the range (maximum-minimum) of PAH concentrations are also given. In calculating the average (Ave) PAH concentrations, data reported as below detectable limits (Bdl), were replaced with half the value of the limit of detection, if available.

The summed vapour phase concentration (ΣPAHs) for Brisbane was much higher than any of the summed particulate concentrations shown in Table 13. In Brisbane, the low molecular weight PAHs, such as naphthalene and its derivatives, were a major fraction of the vapour and particulate phase PAHs, although their reported recoveries were less than 50% (Muller, J.F. et al., 1998). Phenanthrene and pyrene were also present at significant levels in both vapour and particulate phases. Traffic was reported to be the most dominant source of PAHs, since the highest PAH concentrations were observed at sites close to roads with heavy vehicle traffic. During the summer months some of the PAHs, such as chrysene, with high molecular masses and normally associated with particles, were largely present in the vapour phase. The highest PAH concentrations occurred during winter.

PAH levels in Perth were found to be high in a wood smoke-impacted area, Duncraig, compared to Swanbourne and Caversham. The average benzo(a)pyrene level at Duncraig was 7.7 ng/m³ compared to 0.6 and 0.5 ng/m³ at Caversham and Swanbourne respectively. The dominant PAH in Perth was benzo(g,h,i)perylene., followed by benzo(a)pyrene, benzo(b)fluoranthene and benzo(k)fluoranthene.

Acenaphthylene was the dominant PAH detected by industrial self-monitoring in NSW, from 1996 to 1997. Several other PAHs had maximum concentrations above 10 ng/m³.

Benzo(g,h,i)perylene and dibenz(a,h)anthracene were the dominant PAHs measured in Canberra. However, their concentrations were significantly lower than corresponding concentrations measured in other Australian cities.

The Launceston study recorded the highest benzo(a)pyrene concentration—34.3 ng/m³. The highest benzo(a)pyrene peak levels were recorded from air samples taken from East Launceston and Newnham in winter during periods of high haze levels.

The dominant PAH at Debney’s Park was benzo(g,h,i)perylene, a marker for motor vehicle emissions (see page 5), while at Collingwood the dominant PAH was acenaphthene. Both studies showed enhancement in PAH levels during the winter months, attributed to increased motor vehicle use during the colder months, wood burning for domestic heating or stable meteorological conditions leading to a build-up of pollutants.

In addition to the data given in Table 13, the Melbourne Aerosol Study (MAS) reported the concentrations of 10 PAHs in Alphington and Footscray, two suburbs of Melbourne. Table 14 gives these results. This study was designed to examine the ‘worst case’ situation, eg sampling on days with elevated fine particle levels (FPM > 30 µg/m³) and with short sampling times (8 hours). Only those samples with high carbon content were analysed for PAH, with the result that there were only 2 samples for Footscray and 5 for Alphington. The difference between Alphington and Footscray may be attributed to the higher contribution from wood smoke at Alphington. Of the ten PAHs analysed in the MAS study, only six were significantly higher than at Debney’s Park or Collingwood.

Table 14. Average concentration (ng/m³) and range (max-min) for PAHs analysed in the Melbourne Aerosol Study. The annual average data for Melbourne (Debney’s Park and Collingwood) from Table 13 is included as a comparison.

PAH	Alphington	Footscray	Debney’s Park	Collingwood
Anthracene	0.11 (0.17-0.06)	0.08 (0.10-0.06)	0.003 (0.06-bdl)	0.05 (0.09-0.02)
benz(a)anthracene	5.01 (7.30-1.84)	1.06 (1.24-0.87)	0.09 (0.70-0.01)	0.17 (0.43-0.01)
benzo(a)pyrene	13.3 (21.8-7.18)	6.44 (7.55-5.33)	0.1 (1.43- Bdl)	0.17 (0.83-0.02)
benzo(e)pyrene	14.5 (51.0-17.4)	32.9 (17.9-11.2)		0.53 (0.98- Bdl)
chrysene	9.74 (15.12-4.32)	4.2 (5.26-3.13)	0.13 (0.65-0.01)	0.22 (0.47-0.01)
coronene	5.92 (9.58-2.37)	1.86 (1.90-1.82)		0.62 (2.72- Bdl)
Fluoranthene	0.37 (0.66-0.19)	0.33 (0.42-0.23)	0.09 (0.53-0.01)	0.15 (0.52- Bdl)
perylene	19.2 (10.5-28.5)	6.56 (9.10-4.02)		0.078 (0.42- Bdl)
Phenathrene	0.30 (0.41-0.23)	0.33 (0.40-0.26)	0.05 (0.22- Bdl)	0.11 (0.26- Bdl)
Pyrene	1.59 (2.98-0.77)	1.45 (1.66-1.23)	0.13 (0.74-0.01)	0.17 (0.48-0.01)

The values quoted for Debney’s Park and Collingwood are annual averages, compared with data from Alphington and Footscray that are the averages of samples taken during autumn and winter. If the data collected at Debney’s Park during winter is considered independently, a seasonal variation is observed with higher values in winter.

Samples from the Northern Territory were taken at an urban site, Darwin, and a rural site, Jabiru East. The maximum 24-h concentration for benzo(a)pyrene was not reported for Darwin, but would be expected to be higher than the corresponding value of 0.7 ng/m³ reported for Jabiru East. This is because the calculated average benzo(a)pyrene concentration reported for Darwin (0.09 ng/m³) was much greater than the average for Jabiru East (0.02 ng/m³). Benzo(b)fluoranthene was reported to be the dominant PAH species in the Darwin samples, contributing up to 40% of the total PAH, but did not show any seasonal variation. PAH emissions in Darwin were dominated by traffic sources. The similarity between seasonal variation among the PAH species at Jabiru East and Darwin suggested that they had a common source—biomass burning.

For the particulate phase data, the maximum total PAH concentrations, expressed as the sum of the individual PAH concentrations (ΣPAHs), ranged from ~1.0 ng/m³ in Canberra, to ~100 ng/m³ in Perth, Melbourne and the NSW industrial sites. These values were dependent on the averaging times and more importantly on the number of PAHs studied. The range of the

Σ PAHs concentrations in Australian cities is comparable to Σ PAHs concentrations measured in London and Manchester ($\sim 20 - 150 \text{ ng/m}^3$), although the latter were determined for both particulate and vapour phase PAHs (Coleman *et al.*, 1997).

The maximum particulate phase concentrations and averaging times for the dominant PAHs in Australian cities were: benz(a)anthracene (15.3 ng/m^3 , 24h), benzo(a)pyrene (34.3 ng/m^3 , 24h), benzo(b)fluoranthene (22.2 ng/m^3 , 24h), benzo(g,h,i)perylene (38.7 ng/m^3 , 24h), benzo(k)fluoranthene (16.4 ng/m^3 , 24h), chrysene (15.1 ng/m^3 , 8h), dibenz(a,h)anthracene (2.4 ng/m^3 , 24h), fluoranthene (11.5 ng/m^3 , 24h), phenanthrene (9.00 ng/m^3 , 5d) and pyrene (20.0 ng/m^3 , 24h).

Most of the data reported here are consistent with results obtained from earlier studies on PAH concentrations in Australia (Yang *et al.*, 1991, Freeman and Catell, 1990, Lyall and Hooper, 1988, Freeman, 1987). Australian studies, which measured PAH concentrations prior to 1990, were not included in this report.

6. PAH Work in Progress

At present the following environmental agencies are performing ambient PAH monitoring

- NSW EPA
- Environment ACT

The WA Department of Environmental Protection is considering an ambient PAH monitoring project.

The WA Chemistry Centre plans to develop an analytical method involving the thermal desorption of airborne PAHs collected on filter papers. This method should significantly improve PAH detection limits, since samples will not have to be diluted in solvents before analysis.

The Environmental Aerosol Laboratory at the Queensland University of Technology, Queensland is engaged in the following PAH research programs:

- Speciation and quantification of volatile and semi-volatile organic compounds, including PAHs in sub-micrometre particulate samples from indoor air and vehicle emissions.
- Development and application of analytical protocols for real-time monitoring of organic aerosols, in general and PAHs, in particular.
- Metal-catalysed oxidation of environmental PAHs.

Mr Wayne Riley at the ACT Department of Health is supervising research work by Mr Ian Fox, involving PAH monitoring in the Canberra Area (preliminary results of this work have been included in this report).

The NSW EPA has work in progress on ambient PAH monitoring, however, details of the program were not available.

Jochen F. Muller submitted a PhD Research thesis entitled "Occurrence and Distribution Processes of Semivolatile Organic Chemicals in the Atmosphere and Leaves", to the Faculty of Environmental Sciences, Griffith University, Nathan, Queensland, in July 1997.

7. Comparison of Ambient PAH Data in Australian Cities and other Cities around the World

Average PAH concentrations determined in Australian cities are compared with recent concentrations determined from several cities from around the world (Tables 15 & 16). No standard or systematic measurement methods have been used in most of the studies, making data comparison difficult. For example, each study would have unique characteristics for the sampling sites (rural, urban, suburban or industrial), differing methods of sample collection, and varying methods of sample clean-up/analysis; each would be associated with specific analytical uncertainties.

Several studies have reported a dichotomy between summer and winter data, due to the apparently vastly different PAH sources in winter. To make the comparison between cities easier, data in Table 15 and 16 have been grouped as winter data or summer data. For Australian cities, winter data spanned the months June through August and summer data spanned the months December through February.

The average particulate-associated PAH concentrations from urban sites in Australian cities have been compared with corresponding PAH data reported for some urban sites in Birmingham, New Jersey, Seoul and Lahore (Table 15). Summer and winter averages are presented for most of the sites in the Table. Winter PAH concentrations in Australian cities appear to be higher than summer concentrations by a factor of 2-5. This differential has also been observed in several major cities throughout the world (Smith and Harrison, 1998).

In general, ambient particulate bound PAH concentrations in Australian cities were lower than both Birmingham and New Jersey concentrations, which in turn were much lower than the particulate bound PAH concentrations reported for Seoul and Lahore.

The total PAH concentrations reported for Brisbane are compared with similar data from Birmingham, Minneapolis and Stockholm (Table 16). Total PAH concentration comprises of particulate and vapour phase concentrations. In Australia, only the Brisbane study determined the total PAH (vapour and particulate phase) concentration. Data from the Brisbane study (Muller, J.F. *et al.*, 1996a) are comparable to data from the other cities represented in Table 16. Total PAH concentrations in winter are higher than summer concentrations.

The difference between PAH concentrations in winter and summer has been attributed to the following (Smith and Harrison, 1998):

- increase in emissions from domestic heating
- winter traffic (from congestion and cold starts)
- meteorological conditions which favour less pollutant dispersion in winter
- possible loss of PAHs due to photochemical decay in summer

Baek *et al.* (1992) have suggested that in urban areas, particle associated PAHs will peak in winter, while vapour phase PAHs will peak in summer. However, PAHs with high molecular masses are known to peak in winter.

Table 15. Comparison of Average Particulate Phase PAH concentrations in Australia Cities and other Cities (concentrations are in units of ng/m³)

PAH	Perth ^a	Debney's Park ^b	Brisbane ^c	Canberra ^d	Collingwood ^e	Launceston ^f	Birmingham ^g	New Jersey ^h	Seoul ⁱ	Lahore ^j
Acenaphthene	0.030/Bdl		0.002/Bdl		1.48		0.29/1.6		20.6	2.78
Acenaphthylene	0.109/0.097		0.004/0.073		0.17				16.1	
Anthracene	0.006/0.056		0.011/0.093		0.5		0.16/0.39		3.05	4.99
Benz(a)anthracene	0.017/1.445	0.023/0.150	0.069/1.188	0.015	0.17		0.13/1.48	0.15/0.88	0.74	5.39
Benzo(a)pyrene	0.115/3.621	0.040/0.253	0.194/1.520	0.038	0.17	2.019	0.23/0.73	0.21/1.06	1.17	9.32
Benzo(b)fluoranthene	0.270/3.980	0.083/0.330	0.242/1.903	0.048	0.18		0.34/1.87	0.34/1.09	1.65	9.80
Benzo(e)pyrene	0.135/2.240		0.128/1.473		0.53				1.63	
Benzo(g,h,i)perylene	0.318/7.172	0.240/1.030	0.605/4.858	0.211	0.86		0.76/0.76	0.62/1.44	0.83	14.64
Benzo(k)fluoranthene	0.234/3.098	0.037/0.163	0.252/2.160	0.016	0.069		0.14/1.12	0.15/0.63	0.63	4.61
Chrysene	0.045/1.565	0.053/0.187	0.118/1.808		0.22		0.21/2.21	0.52/2.42	1.67	8.64
Coronene			0.222/Bdl		0.62		0.27/1.03	0.37/0.52	0.24	5.40
dibenz(a,h)anthracene	0.035/0.217	0.033/0.117		0.036	0.67		0.07/1.78		1.46	3.85
Fluoranthene	0.047/0.314	0.037/0.120	0.052/1.135		0.15		0.35/1.17		1.65	2.81
Fluorene	0.138/0.106		0.006/0.115				0.21/1.06		1.12	0.98
Indeno(1,2,3-c,d)pyrene	0.248/2.847	0.093/0.433	0.203/2.875		0.41		0.42/1.95	0.37/0.98	0.79	12.31
Naphthalene	0.968/2.143		0.358/1.788		0.45				5.99	
Perylene	0.027/0.538		0.022/0.193		0.078				0.1	
Phenanthrene	0.245/2.78		0.077/0.760		0.11		0.25/1.08		0.45	0.97
Pyrene	0.071/0.409	0.050/0.153	0.171/1.953	0.040	0.17		0.55/2.36	0.35/2.77	0.69	2.93

^aPerth: Gras, 1996

^bDebney's Park: VicRoads/EPA, 1991

^cBrisbane: Muller, J.F. et al., 1996a

^dCanberra: Fox, I., 1999

^eCollingwood: Panther et al., 1999

^fLaunceston: Expert Working Party, 1996

^gBirmingham: Harrison et al., 1996

^hNew Jersey: Greenberg et al., 1985

ⁱSeoul, S. Korea: Panther et al., 1999

^jLahore, Pakistan: Smith et al., 1996

References for Other Cities

^gBirmingham: Harrison et al., 1996

^hNew Jersey: Greenberg et al., 1985

ⁱSeoul, S. Korea: Panther et al., 1999

^jLahore, Pakistan: Smith et al., 1996

Table 16. Comparison of Average Total PAH concentrations (ng/m³)

Total PAH ^a	Brisbane ^b	Birmingham ^c	Minneapolis ^d	Stockholm ^e
Acenaphthene	2.620/9.418	4.23/13.5	/6.9	
Acenaphthylene	4.422/36.64		/51	0.8
Anthracene	1.489/4.343	0.61/4.49	/3.7	1.4
Benz(a)anthracene	0.218/1.218	0.345/5.9	/1.8	0.4
Benzo(a)pyrene	0.212/1.540	0.25/0.81	/0.3	0.2
Benzo(b)fluoranthene	0.400/1.920	0.38/2.15	/2.3	
Benzo(e)pyrene	0.147/1.485			0.4
Benzo(g,h,i)perylene	0.605/4.865	0.76/0.83		0.5
Benzo(k)fluoranthene	0.248/2.173	0.16/1.2	/1.5	
Chrysene	0.509/1.990	0.61/6.49	/3.0	0.8
Coronene	0.222/Bdl	0.271/0.3		0.3
Fluoranthene	2.390/7.553	2.11/12.4	/11	
Fluorene	3.845/33.20	7/13.7	/15	
Indeno(1,2,3-c,d)pyrene	0.203/2.875	0.42/1.96		
Naphthalene	63.98/97.05			
Perylene	0.018/0.193			
Phenanthrene	13.98/35.50	3.84/24.1	/38	
Pyrene	4.39/13.80	3.33/38	/10	

"/" summer/winter concentrations

^a Vapour + particle concentration

^b Brisbane: Muller, J.F. et al., 1996a

^c Birmingham: Harrison et al., 1996

^d Minneapolis: Hawthorne et al., 1992

^e Stockholm: Ostman et al., 1992a,b

8. Health Impacts

Human exposure to PAHs occurs principally by direct inhalation, ingestion or dermal contact, as a result of the widespread presence and persistence of PAHs in the urban environment. PAHs are important environmental and occupational carcinogens and figure prominently in risk assessments for hazardous waste sites; coal-fired, municipal and hazardous waste incinerators and industrial property transfers. Several PAHs, including benz(a)anthracene, benzo(a)pyrene, benzo(b)fluoranthene, chrysene, dibenz(a,h)anthracene and indeno(1,2,3-c,d)pyrene have been shown to cause tumours in laboratory animals. Benzo(a)pyrene and pyrene are the most important carcinogenic PAHs and are components of combustion processes, coke oven and foundry emissions, cigarette smoke and charcoal-grilled meats (Dellomo and Lauwerys, 1993).

8.1 Ambient Standards

There are no ambient air quality standards for PAHs. In Europe, the Netherlands introduced an interim goal of reducing the annual average benzo(a)pyrene concentration to below 5 ng/m³ (Smith and Harrison, 1998), while a guideline of 10 ng/m³ for the annual average benzo(a)pyrene has been proposed by the German Federal Environmental Agency (Smith and Harrison, 1998).

Composite annual averages of benzo(a)pyrene in Australian and European cities appear to be below available European guidelines. PAHs are among the list of hazardous air pollutants to be regulated under the US Clean Air Act Amendments, 1990.

Recently, the Dutch National Institute of Public Health and the Environment (DNIPHE) determined values of maximum permissible concentrations (MPCs) and negligible concentrations (NCs) for about 200 toxic compounds including some PAHs (RIVM, 1999a). The MPCs and NCs represent risk limits of the substances in different compartments of the environment—surface water, soil, air, groundwater and sediment, and are calculated from available ecotoxicological data. These risk limits are used to derive environmental quality standards in the Netherlands (RIVM, 1999b).

Of the seven PAHs in the Dutch report, only benzo(a)pyrene had ecotoxicological data available for air. Thus MPCs and NCs for air were not available for the other six PAHs. However, the DNIPHE assigned a critical concentration value in air to each of them (Table 17). Critical concentrations are normally calculated for air and/or rainwater. They are theoretically derived steady-state concentrations of the pollutants in air and/or rainwater that will not lead to exceedance of the MPC value for soil (RIVM, 1999a).

Calculated MPCs, NCs and critical concentrations of PAHs reported in the DNIPHE report (RIVM, 1999a) are compared to the highest composite annual average concentrations determined for Australian cities (Table 17). Only data from Table 13, which could be taken as representative of annual average data, were considered. Perth had the highest composite annual average benzo(a)pyrene concentration measured in Australian cities. This value, 1.88 ng/m³, was greater than the DNIPHE maximum

permissible concentration. The next highest, 1.77 ng/m³ from Launceston, was also greater than the MPC value for benzo(a)pyrene. The other PAHs in the table have average concentrations much less than the DNIPHE critical concentrations.

Table 17. Average Concentrations of some PAHs in Australian Cities compared to the Dutch National Institute of Public Health and the Environment (DNIPHE) Maximum Permissible Concentration (MPCs), Negligible Concentrations (NCs) and Critical Concentrations (CritConc)

PAH	*Average 24-h Concentration in Australian Cities (ng/m ³)	MPC[air] (ng/m ³)	NC[air] (ng/m ³)	CritConc[air] (ng/m ³)
Anthracene	1.64	-	-	8,600
Benz(a)anthracene	0.72	-	-	200
Benzo(a)pyrene	1.88	1.0	0.01	
Benzo(k)fluoranthene	1.68	-	-	200
Fluoranthene	2.92	-	-	1300
Naphthalene	57.3	-	-	140,000
Phenanthrene	20.3	-	-	33,000

**Highest annual average determined for any Australian city (1990-1999)*

8.2 Human Health Effects of Exposure to PAHs

Human exposure to ambient PAH is usually in combination with other PAHs and other substances. For example, exposure in iron and steel foundries entails exposure to PAHs and other potentially carcinogenic substances such as nickel, chromium, silica, soot, asbestos and benzene. Consequently, estimating the risk associated with exposure to specific PAHs requires controlled experimental data; otherwise, other substances may be responsible for the health outcome or may be interacting with the PAH of interest. Substances besides PAHs may account for a more significant portion of the carcinogenicity of some mixtures, such as cigarette smoke, diesel emissions and urban aerosol (IPCS, 1998).

Isolating the health effects associated with exposure to specific PAHs has been limited to experimental studies involving volunteers and accidental exposure of children to naphthalene. Acute haemolytic anaemia in babies is a typical systemic effect of naphthalene inhalation from mothball treated wool blankets. Experimental studies involving voluntary exposure to naphthalene have excluded the inhalation route, focussing instead on dermal absorption. Investigations of the pulmonary absorption of PAHs are hindered by the mucociliary clearance mechanism in which hydrocarbons absorbed onto particulates that have been inhaled are removed from the lungs and ingested.

Besides accidental exposure to naphthalene, there do not appear to be acute toxicity risks associated with PAH exposure. Long-term health risks, other than cancer, have rarely

been reported. The IPCS Environmental Health Criteria summary on PAHs indicates that numerous PAHs may be both carcinogenic and genotoxic. Of the 33 PAHs which have received attention, 26 are described as carcinogenic (IPCS, 1998).

Most of the data collected on the human health effects of PAH exposure arise from epidemiological studies conducted in the occupational setting. There is a large body of evidence supporting an excess risk of lung cancer in workers exposed to mixtures of PAHs at coke ovens, coal gasification plants, petroleum refineries, aluminium smelters, iron and steel foundries and with bitumen, diesel and asphalt. The highest PAH levels are probably found in coke ovens, although the levels to which workers are exposed are not described in most epidemiological studies.

Numerous studies of coke oven workers have provided evidence of a dose-response relationship between numerous PAHs and health endpoints, including lung cancer and depressed immune function. However, uncertainty surrounds the presence of a dose-response relationship between PAHs and lung cancer in aluminium plant workers. Other health outcomes associated with PAH exposure in aluminium plant workers include urinary bladder cancer, asthma-like symptoms, lung function abnormalities and chronic bronchitis. In foundry workers, research indicates that PAH exposure is associated with a greater risk of lung cancer, silicosis and other chronic respiratory abnormalities.

Although most studies reviewed in the IPCS monogram were case-control and cohort studies, only a few controlled for the confounding potential of cigarette smoking (IPCS, 1998). Of these studies, significant associations between PAHs and lung cancer remained after controlling for smoking. Another reason for excluding tobacco smoking as a confounder is that study controls were often workers with other occupations. It is therefore likely that their tobacco smoking habits were similar to those of the study cases and that the increased risks are subsequently due to exposure conditions and not tobacco smoking. As well as being a potential confounder of the association between PAHs and a health effect, tobacco smoke may interact with the exposure of interest. There appears to be little consideration of interaction effects in any studies of PAHs and health effects.

Tobacco smoke is the single most studied risk factor for a range of internal and skin cancers. Sidestream cigarette smoke contains higher levels of PAHs and is more carcinogenic than mainstream smoke. One study found 83% of the total carcinogenic activity of sidestream smoke was due to PAHs (Grimmer *et al.*, 1998; cited in IPCS, 1998). There are no studies measuring the association of specific PAHs in cigarette smoke with health effects.

Besides tobacco smoke, the greatest risk to human health from indoor exposure to PAHs is from unvented coal combustion in homes. High mortality from lung cancer in a Chinese rural county lead Mumford *et al.* (1987; cited in IPCS, 1998) to measure the correlation between the lung cancer mortality rate and the domestic use of smoky coal in the Province. Indoor benzo(a)pyrene levels, from the burning of smoky coal, approached levels typically found in coke oven factories ($14.7 \mu\text{g}/\text{m}^3$).

Given the long term evidence suggesting PAHs elevate the risk of various cancers, immunotoxic and respiratory problems, the IPCS made a number of recommendations for the protection of human health (IPCS, 1998). These recommendations included eliminating or minimising emissions in occupational settings, improved monitoring of urban air pollution and public education. The complexity of investigating the health effects associated with PAH exposure in the ambient air is reflected in the absence of research addressing this issue to date.

8.3 PAH Potencies

PAH potencies are used to determine quantitative health risks posed by PAH exposure. The risks posed by a mixture of PAHs are based on an assumption of additivity of the individual risks posed by the PAHs. The IPCS monogram on PAHs (IPCS, 1998) describes three approaches used to calculate PAH potencies: 1) toxicity equivalence factors approach is based on expressing of individual potencies relative to benzo(a)pyrene, 2) comparative potency approach, which does not identify or quantify the individual compounds but determines the potency of the mixture of compounds and 3) benzo(a)pyrene surrogate approach assumes that benzo(a)pyrene is an indicator of all the PAHs.

The toxicity equivalence approach estimates the individual PAH potencies relative to that of benzo(a)pyrene, in order to obtain a benzo(a)pyrene equivalent (Albert *et al.*, 1983). There are several toxicity equivalence models used to determine relative potency values. Data determined from some studies are in Table 18. Krewski *et al.* (1989) based their data on estimates from a two-phase model of results from 11 experimental studies, (Clement Associates, 1988). Muller, P. *et al.* (1995a,b, 1996) data were derived from PAH profiles of a wide range of mixtures from many sources.

There is a reasonable degree of agreement between the relative potencies calculated by different toxicity equivalence approaches for the carcinogenic PAHs (IPCS, 1998). Dibenz(a,h)anthracene appears to be equipotent to (or more potent) than benzo(a)pyrene, while the benzofluoranthenes and benzoanthracene were 1% to 10% as potent as benzo(a)pyrene. Anthanthrene has a significant potency value compared to several other PAHs in Table 18, but was not determined in most of the Australian studies. Nine of the ten-most studied PAHs in Australian cities—benz(a)anthracene, benzo(a)pyrene, benzo(b)fluoranthene, benzo(g,h,i)perylene, benzo(k)fluoranthene, chrysene, dibenz(a,h)anthracene, phenanthrene and pyrene are present in Table 18. Fluoranthene is not in the table. The Table is useful in that it provides an estimate of the relative health risks posed by some PAHs, which occur frequently in the air environment.

Table 18. Relative Potencies^a of PAHs

PAH	Krewski <i>et al.</i> , 1989	Muller, P. <i>et al.</i> , 1995a,b; 1996
Anthanthrene	0.320	0.28
Benz(a)anthracene	0.145	0.014
Benzo(a)pyrene	1.00	1.0
Benzo(b)fluoranthene	0.141	0.11
Benzo(e)pyrene	0.004	0
Benzo(g,h,i)perylene	0.022	0.012
Benzo(j)fluoranthene	0.061	0.045
Benzo(k)fluoranthene	0.066	0.037
Chrysene	0.0044	0.026
Cyclopenta(c,d)pyrene	0.023	0.012
Dibenz(a,h)anthracene	1.11	0.89
Dibenzo(a,l)pyrene		100
Dibenzo(a,e)fluoranthene		1.0
Dibenzo(a,h)pyrene		1.2
Indeno(1,2,3-c,d)pyrene	0.232	0.067
Phenanthrene		0.00064
Pyrene	0.081	

^aPotency units equivalent to benzo(a)pyrene

8.4 PAH Mutagenicity

Morris *et al.* (1995) examined PAH extracts of air borne particles for their magnetic susceptibility. The particles were collected in Hamilton, a heavily industrialised urban centre in Lake Ontario, from May 1990 to June 1991. There was a significant correlation ($R=0.89$) between the magnetic susceptibility and the mutagenic potencies of the PAH extracts in Salmonella/microsome assays. No direct relationship was found between magnetic susceptibility or mutagenicity and particle loading. However, the enhanced magnetic signatures could be attributed to the presence of magnetite-rich particles, possibly formed by the oxidation of pyrite to magnetite during combustion processes in the large steel mills, which are upwind of the sampling sites.

The finding here is significant since it implies that magnetic susceptibility could be used as a rapid screening method for PAH samples, from steel mills, with high mutagenic potential.

Bioassay-directed chemical analysis is a technique used to isolate important chemical mutagens in environmental samples, which contain a complex mixture of thousands of chemical species. Bacterial assays have been used as biological end points for most bioassay-directed chemical analysis for mutagens. For example, for emission sources, Nishioka *et al.* (1982) found that nitro-polycyclic aromatic compounds (nitro-PAC) accounted for 20-25% of the bacterial mutagenic activity observed without further enzymatic activation of the assay (ie, no “-S9 test”) of diesel exhaust extracts. Salmeen

et al. (1984) found that mono- and dinitro- PACs account for 30-40% of the bacterial mutagenicity (-S9) of diesel exhaust emissions.

In the case of ambient particles, Wise *et al.* (1985) reported significant bacterial mutagenic activity (-S9) due to nitro-PAC in air, while Arey *et al.* (1988) found that nitro-PAC accounted for only 1-8% of the bacterial mutagenic activity (-S9). Helmig *et al.* (1992) concluded that a specific nitro-PAC (2-nitro-6H-dibenzo(b,d)pyran-6-one) accounted for ~45% of the bacterial mutagenic activity (-S9) of their ambient samples.

There have been a few studies that did not use bacterial assays as biological end points. Grimmer *et al.* (1982, 1983, 1984) studied extracts of particulate matter from several air pollutant emission sources using carcinogenic effects in rats as an end point, and found unsubstituted PACs with three rings to account for the total carcinogenic activity.

Skopek *et al.* (1979) found that 8% of the observed activity of kerosene soot was due to cyclopenta(c,d)pyrene when they used a human cell forward mutation assay. Using the same assay, Barfknecht *et al.* (1982) reported that a significant fraction of the activity of diesel engine exhaust was due to fluoranthene. Durant *et al.* (1994) found that benzo(a)pyrene accounted for as much as 50% of the activity of the MCL-5 human cell line of all the organics extracted from an urban pond sediment.

Table 19. Individual PAH contributions to Human Mutagenicity of Los Angeles Airborne Fine Particle¹

PAH	IMF ($\times 10^6$)/mg of EOC ²	Known sources in Los Angeles ³
Cyclopenta(c,d)pyrene	12.9 – 5.31	non-catalyst petrol MV ⁴ exhausts
Benzo(a)pyrene	3.72 – 0.87	non-catalyst petrol MV exhausts
Benzo(g,h,i)perylene	2.43-0.36	non-catalyst petrol MV exhausts
Benzo(b)fluoranthene	2.06-0.51	MV and natural gas combustion
Indeno(1,2,3-c,d)pyrene	1.73-0.23	non-catalyst petrol MV exhausts
Benzo(k)fluoranthene	1.17-0.26	MV and natural gas combustion

¹Whole sample mutagenic potency was 150 IMF ($\times 10^6$)/mg of EOC (Hannigan *et al.* (1998).

²Induced Mutant Fraction (IMF) per units of Equivalent Organic Carbon (EOC).

³Lafleur & Wornat, 1988.

⁴MV: Motor vehicles

Recently Hannigan *et al.* (1998) examined the human cell mutagenicity of Los Angeles airborne fine particulate matter, and found subfractions containing unsubstituted polycyclic aromatic compounds (PACs) responsible for a considerable portion of the mutagenic potency of the whole atmospheric sample. Six unsubstituted PAHs (cyclopenta(c,d)pyrene, benzo(a)pyrene, benzo(g,h,i)perylene, benzo(b)fluoranthene, indeno(1,2,3-c,d)pyrene and benzo(k)fluoranthene) accounted for most of the mutagenic potencies that could be assigned to specific compounds within the atmospheric samples (Table 19).

8.5 PAH Biomarkers

Biomarkers are used for the direct measurement of biological events or responses that result from human exposure to xenobiotics. They reflect molecular or cellular alterations that occur along the temporal and mechanistic pathways connecting ambient exposure to toxic chemicals and the presence or risk of clinical disease. Hematological changes accompanying high levels of exposure to lead or benzene are biomarkers of chemical exposure. PAH-DNA adducts and hemoglobin-DNA adducts are examples of biomarkers used in several studies of occupational exposure to PAHs. There have been only few studies that have reported examining biomarkers of environmental PAH exposure. Decaprio (1997) has reviewed the application of biomarker technology in environmental epidemiology and summarized recent biomarker data for benzo(a)pyrene, 1,3-butadiene and acrylamide.

Three classes of biomarkers are relevant for purposes of molecular epidemiology and risk assessment. Exposure biomarkers measure the actual absorbed dose and extent of delivery of the xenobiotic to the target site. Effect biomarkers measure early biological or cellular responses in target or non-target tissue. Susceptibility biomarkers reveal individuals with genetically mediated predisposition to xenobiotic induced toxicity.

Cumulative DNA adduct data for human exposure to PAHs show a generally positive correlation between adduction and exposure levels over a large ambient concentration range (Hemminki *et al.*, 1990, cited in Decaprio, 1997). The PAH biomarker database represents one of the most extensive available for application to epidemiology and risk assessment.

8.6 Ecological Impacts of PAHs

There has been little investigation of the ecological impact of PAHs. There is limited evidence of ecotoxic effects in terrestrial and aquatic organisms. No data were available on the effects of PAH on plants, wild mammals, or birds. PAH levels in soil are generally below the no observed adverse effect level (NOAEL) for the survival and reproduction of earthworm species.

PAHs may induce neoplastic effects in aquatic organisms. The toxic effect of naphthalene, phenanthrene, fluoranthene and benzopyrene on aquatic organisms has been well studied in the laboratory. Phenanthrene is the PAH found in highest concentrations in aquatic samples. In reality, only sediment dwelling organisms are likely to be adversely affected by these PAHs as the sediment acts as a sink for PAHs. Hepatic tumours have been reported in sediment dwelling fish, although PAH sediment levels are usually lower than those found in these studies. The ecological significance of the carcinogenic effects of PAH in fish has not been assessed (IPCS, 1998).

9. Summary of Findings

There have been eight main studies of PAH concentrations in Australian cities since 1990. The studies reported here were done in: Brisbane (July 1994 to June 1995), Perth (April 1994 to July 1995), Darwin and Jabiru East (December 1994 to July 1997), Canberra (September 1996 to March 1997), Launceston and the Upper Tamar Valley (July 1991 to September 1993), Melbourne at Debney's Park (November 1990 to October 1991), at Footscray and Alphington (May to June, 1990) and at Collingwood (January to December, 1993). A comprehensive study of PAHs has also been conducted in NSW, however the results were not available. Industrial self-monitoring data collected under conditions of NSW EPA discharge licences in 1996 and 1997 have been included in this report.

It was difficult to compare PAH data between different jurisdictions, because of the varying methods used to determine them. Different suites of PAH compounds were studied and only one study, the Brisbane Study, measured both particulate and vapour phase PAH; the others measured only particle bound PAHs. The Brisbane data showed a larger portion of the PAHs were in the vapour fraction.

Acenaphthylene appeared to be the dominant PAH, as revealed by industrial self-monitoring, in NSW while benzo(g,h,i)perylene and dibenz(a,h)anthracene dominated in Canberra and in Brisbane naphthalene with its derivatives were present at high concentrations in the vapour and particulate phases. Benzo(a)pyrene was the only PAH reported for Launceston study and the Northern Territory study at Darwin and Jabiru East. PAH values from the Melbourne Aerosol Study (MAS) were higher than values obtained from the Debney's Park Study. The dominant PAHs from the MAS were benzo(e)pyrene, benzo(a)pyrene, perylene, and chrysene. The dominant PAH from the Collingwood study was acenaphthene. The dominant PAH in Perth was benzo(g,h,i)perylene, followed by benzo(a)pyrene.

Based on the literature reviewed, the presence of chrysene and benzo(k)fluoranthene may be indicators for coal combustion emissions. Whereas other PAHs are indicators of other combustion process: benzo(g,h,i)perylene, coronene and phenanthrene are indicators for motor vehicle emissions, pyrene and fluoranthene are associated with incineration and fluorene, fluoranthene and pyrene are associated with oil combustion. Indicators for road salt particles, from salting roads with salt, are phenanthrene, fluoranthene and pyrene. All these PAHs were identified in the Australian studies.

In most of the Australian studies, PAH emissions were attributed to domestic heating in winter. PAH levels in Perth were found to be high in a wood smoke-impacted area, Duncraig. The Launceston study recorded the highest 24-hour average benzo(a)pyrene concentration, 34.3 ng/m³, during periods of haze levels in winter.

The Melbourne Aerosol Study (MAS) and the Debney's Park studies showed enhancement in PAH levels during the winter months, and attributed it to increased motor vehicle use during the colder months, wood burning for domestic heating or stable

meteorological conditions leading to a build-up of pollution. PAHs in Collingwood were found to be higher during the cold winter season and lower during the warm summer. The increased PAH emissions here were attributed to the use of fossil fuels for heating in the winter.

Darwin PAH emissions were dominated by traffic sources. The similarity between seasonal variation among the PAHs at Jabiru East and Darwin suggested that they had a common source—biomass burning.

The Brisbane study attributed PAHs to motor vehicle emissions. Traffic was found to be the most dominant source of PAHs in Brisbane, since the highest PAH concentrations in Brisbane were observed at sites close to roads with heavy vehicle traffic.

PAH concentrations measured in Canberra were considerably lower than corresponding concentrations measured in other Australian cities.

At present, ambient PAH monitoring is being done by the NSW EPA and Environment ACT. The Environmental Aerosol Laboratory at the Queensland University of Technology, Queensland is engaged in PAH research.

Most of the Australian studies involved the collection of total suspended particles (TSP), however, some studies (Perth and Canberra) used size-selective inlets to collect particulate matter with aerodynamic diameters of 10 μm or less (PM10). Most samples were collected onto glass fibre filters located in high volume samplers, which run for 24 hours. The sampling frequency, times and rates varied with the different jurisdictions. The following artefacts tend to arise from sampling: degradation of collected PAHs; breakthrough of PAHs from the adsorbent; adsorption of vapour phase PAHs onto filters or onto particles on filters and volatilisation of PAHs from filter-retained particles. Using slower sampling rates or inert filters can reduce artefact formation.

Although there were several different sampling regimes used for collecting samples, more standardised methods were used for chemical analyses of PAH.

PAHs were extracted from their collection media by ultrasonic agitation of the particulates in polar solvents, which was much faster than the more efficient traditional Soxhlet extraction method. One study used supercritical fluid extraction (SFE) to extract the PAH samples. The extracts were cleaned to remove contaminants, prior to chemical analysis to identify and quantify the PAHs. Several of the studies, however, did not report cleaning the extracts.

The most common instrumental method of analysis for PAHs, was gas chromatography-mass spectrometry (GC/MS) and the other was high performance liquid chromatography (HPLC), using UV-visible or fluorescence detection. These techniques enabled separation and quantification of PAH in the nanogram per cubic metre (ng/m^3) ambient concentration range.

HPLC is generally less suitable for separating samples containing complex PAH mixtures. However, the UV or fluorescence detectors used in HPLC are highly specific and sensitive. Also, HPLC can resolve the peaks of various PAH isomers that cannot adequately be resolved by other analytical instruments.

There have been no reports on the use of capillary electrophoresis (CE) methods for the determination of airborne PAHs in Australian cities, although this method has emerged as an important separation tool in chemical analysis and has the potential to rival traditional separation techniques.

Photoelectric aerosol sensors (PAS) can be used for real-time PAH particulate monitoring but they do not provide speciated PAH concentrations. They could be useful for determining hot spots for measuring PAHs by conventional methods. Similar devices were used in the Perth study.

Since no standard or systematic measurement methods have been used in most of the studies across Australia, and it is desirable to compare data across jurisdictions, the following recommendations are suggested for PAH measurements:

- It is recommended that both particulate phase and vapour phase PAHs be collected. Glass fibre filters should be used for particulate bound PAHs and Amberlite XAD-2³ resin, sandwiched between two polyurethane foam absorbents, should be used to collect vapour phase PAHs. Vapour phase PAHs do not have to be collected if it can be shown that they will have negligible human health impacts at the concentrations monitored.
- Sampling should follow the procedures outlined in Australian Standard 3580.9.6 (Determination of Suspended Matter (PM10) Size Selective Inlet Method, 1990). This requires the sampling of particulate matter with aerodynamic diameter of 10 µm or less. Twenty-four hour samples should be collected at a frequency of at least one sample per site within six days.
- The analytical method outlined in US EPA method TO-13, a validated standard method, should be used for determining 19 PAHs in ambient air samples using GC/MS or HPLC. The method requires the use of internal standards and surrogate compounds for calibration and determination of extraction efficiencies.
- In addition, PAHs known to be indicators of pollutant sources and/or carcinogenic should be measured, especially if known to be present.
- Investigation of the use of supercritical fluid extraction (SFE) for the rapid and efficient extraction of PAHs from ambient is also recommended. Finally, capillary electrophoresis (CE) methods should be investigated for use in PAH determination.

Available analytical results from PAH studies done in Australian cities, from 1990 to 1999, showed that the most studied PAHs (with the maximum reported particulate phase concentrations and averaging times) were: benz(a)anthracene (15.3 ng/m³, 24h), benzo(a)pyrene (34.3 ng/m³, 24h), benzo(b)fluoranthene (22.2 ng/m³, 24h),

³ The use of propriety names here does not mean endorsement of these brands.

benzo(g,h,i)perylene (38.7 ng/m³, 24h), benzo(k)fluoranthene (16.4 ng/m³, 24h), chrysene (15.1 ng/m³, 8h), dibenz(a,h)anthracene (2.4 ng/m³, 24h), fluoranthene (11.5 ng/m³, 24h), phenanthrene (9.00 ng/m³, 5d) and pyrene (20.0 ng/m³, 24h)—their concentrations have been reported in at least six studies. Benzo(a)pyrene was the most reported PAH, its concentration was reported in all the studies.

PAH concentrations in Australian cities were comparable to similar data reported in the international literature. Winter PAH concentrations appear to be higher than summer concentrations by a factor of 2-5 and this differential has also been reported in overseas studies.

There are no ambient air quality standards for PAHs. Composite annual averages of benzo(a)pyrene in Australian and European cities appear to be below available European guidelines. The Dutch National Institute of Public Health and the Environment (DNIPHE) has determined maximum permissible concentrations (MPCs) for toxic compounds. These MPCs represent risk limits. It appears that the highest annual average benzo(a)pyrene concentration in two Australian cities, Perth (1.88 ng/m³) and Launceston (1.77 ng/m³), were greater than the DNIPHE calculated MPC value for benzo(a)pyrene, in ambient air (1.0 ng/m³). In the absence of ecotoxicological data, the DNIPHE calculated critical concentration values for six PAHs. The highest annual average concentrations of these six PAHs (anthracene, benz(a)anthracene, benzo(k)fluoranthene, fluoranthene, naphthalene and phenanthrene) determined from any of the Australian cities were well below the DNIPHE critical concentration values.

Human exposure to ambient PAHs is usually in combination with other toxic substances. Consequently, estimating the risk associated with exposure to specific PAHs requires controlled experimental data. The complexity of investigating the health effects associated with PAH exposure in the ambient air is reflected in the absence of research addressing this issue to date.

Most of the data collected on the human health effects of PAH exposure arise from epidemiological studies conducted in the occupational setting. There is a large body of evidence supporting an excess risk of lung cancer in workers exposed to mixtures of PAHs at coke ovens, coal gasification plants, petroleum refineries, aluminium smelters, iron and steel foundries and with bitumen, diesel and asphalt. Besides tobacco smoke, the greatest risk to human health from indoor exposure to PAHs is from unvented coal combustion in homes. Long term exposure to PAHs elevates the risk of various cancers and immunotoxic and respiratory problems.

Nine of the ten-most studied PAHs in Australian cities—benz(a)anthracene, benzo(a)pyrene, benzo(b)fluoranthene, benzo(g,h,i)perylene, benzo(k)fluoranthene, chrysene, dibenz(a,h)anthracene, phenanthrene and pyrene have assigned toxicity equivalence potency values which are based on benzo(a)pyrene toxicity. These potencies can be used in health risk assessment studies.

The reviewed literature showed that PAH mutagenicities were determined from bioassay-directed chemical analysis, which is a technique used to isolate important chemical mutagens in environmental samples. Bacterial assays have been used as biological end points for most bioassay-directed chemical analysis for mutagens.

There is a large research database on the use of biological markers (biomarkers) such as PAH-DNA adducts, to assess PAH-exposure and effect. Cumulative DNA adduct data for human exposure to PAHs show a generally positive correlation between adduction and exposure levels over a large ambient concentration range

There is limited evidence of ecological impacts of PAHs on terrestrial and aquatic organisms. No data was available on the effects of PAH on plants, wild mammals, or birds.

A number of recommendations for the protection of human health from PAH exposure, suggested by the WHO's International Programme on Chemical Safety, included: eliminating or minimising emissions in occupational settings, improved monitoring of urban air pollution and public education.

10. References

- Agnesod, G., DeMaria, R., Fontana, M. and Zublena, M., **1996**. Determination of PAH in airborne particulates: comparison between off-line sampling techniques and an automatic analyser based on a photoelectric aerosol sensor. *Sci. Tot. Environ.*, 189/190, 443-449.
- Albert, R.E., Lewtas, J., Nesnow, S., Thorslund, T.W. and Anderson, E., **1983**. Comparative potency method for cancer risk assessment: Application to diesel particulate emission. *Risk Anal.*, 3, 101-117.
- Arey, J., Zielinska, B, Harger, W.P., Atkinson, R. and Winer, A.M., **1988**. *Mutat. Res.*, 207, 45-51.
- Baek, S.O., **1988**. "Significance and Behaviour of Polycyclic Aromatic Hydrocarbons in Urban Ambient Air", PhD Thesis, University of London.
- Baek, S.O., Goldstone, M.E., Kirk, P.W.W., Lester, J.N. and Perry, R., **1992**. Concentrations of particulate and gaseous polycyclic aromatic hydrocarbons in London air following a reduction in the lead content of petrol in the United Kingdom. *Sci. Total Environ.*, 111, 169-199.
- Baek, S.O., Goldstone, M.E., Kirk, P.W.W., Lester, J.N. and Perry, R., **1991a**. *Environ. Technol.*, 12, 107-129.
- Baek, S.O., Field, R.A., Goldstone, M.E., Kirk, P.W.W., Lester, J.N. and Perry, R., **1991b**. *Water, Air Soil Pollut.*, 60, 279-299.
- Barfknecht, T.R., Hites, R.A., Cavalieri, E.L. and Thilly, W.G., **1982**. In "Toxicological Effects of Emissions from Diesel Engines", J. Lewtas, Ed., Elsevier Science Publishing Co., NY, pp. 277-294.
- Brasser, L.J., **1980**. Polycyclic aromatic hydrocarbon concentrations in the Netherlands. VDI-Berichte Nr., 348, 171-180.
- Broddin, G., Cautreels, W. and Van Cauwenberghe, K.A., **1980**. On the aliphatic and polyaromatic hydrocarbon levels in urban and background aerosols from Belgium and the Netherlands, *Atmos. Environ.*, 14, 895-910.
- Clement Associates, **1988**. "Comparative Potency Approach for Estimating the Cancer Risk Associated with Exposure to Mixtures of Polycyclic Aromatic Hydrocarbons", ICF-Clement Associates, Interim Final Report (Report No. 68-02-4403), Fairfax, Virginia, 125 pp.

- Coleman, P.J., Lee, R.G.M., Alcock, R.E. and Jones, K.C., **1997**. Observations on PAH, PCB, and PCDD/F trends in U.K. urban air, 1991-1995. *Environ. Sci. Technol.*, 31(7), 2120-2124.
- Colmsjo, A.L., Zebuhr, Y.U. and Ostman, C.E., **1986**. Polynuclear aromatic compounds in the flue gases and ambient air in the vicinity of a municipal incineration plant. *Atmos. Environ.*, 20, 2279-2282.
- Dabek-Zlotorzynska, E., **1997**. Capillary electrophoresis in the determination of pollutants. *Electrophoresis*, 18, 2453-2464.
- Dabek-Zlotorzynska, E. and Lai, E.P.C., **1996**. *J. Cap. Elec.*, 3, 31-35.
- Daisey, J.M. and Gundel, L.A., **1993**. Method 20: Determination of extractable particulate organic matter and selected polycyclic aromatic hydrocarbons. In "Environmental Carcinogens. Methods of Analysis and Exposure Measurement: Volume 12. Indoor Air", B. Seifert, H.J. van de Wiel, B. Dodet & I.K. O'Neill. Eds. International Agency for Research on Cancer (IARC Scientific Publications, No. 109), Lyon, pp. 314-327.
- Decaprio, A.L. **1997**. Biomarkers: Coming of age for environmental health and risk assessment. *Environ. Sci. Technol.*, 31(7), 1837-1848.
- Dellomo, M. and Lauwerys, R.R., **1993**. *Crit. Rev. Toxicol.*, 23, 111-126.
- Denison, L.S., **1998**, "State of Knowledge on Airborne Particles in Australia and New Zealand: Draft Report to ANZECC", Environment Protection Authority Victoria.
- Durant, J.L., Thilly, W.G, Hemmond, H.F, and Lafleur, A.L., **1994**. *Environ. Sci. Technol.*, 28, 2033-2044.
- Eatough, D.J., Wadsworth, A., Eatough, D.A., Crawford, J.W., Hansen, L.D. and Lewis, E.A., **1993**. *Atmos. Environ.*, 27, 1213-1219.
- Expert Working Party, **1996**. "Report on an Investigation by an Expert Working Party into Air Pollution Environmental Health and Respiratory Diseases: Launceston and Upper Tamar Valley, Tasmania, 1991-1994", The Launceston City Council, Launceston.
- Fox, I., **1999**. Personal Communications.
- Franck, H.G. and Stadelhofer, J.W., **1987**. "Industrial Aromatic Chemistry. Raw Products, Processes, Products", Berlin, Springer-Verlag, pp 308-380.
- Freeman, D.J., 1987. Polycyclic Aromatic Hydrocarbons in Sydney Brown Haze. Submitted for the degree of Doctor of Philosophy, Macquarie University, Australia.

- Freeman, D.J. and Catell, F.C.R., **1990**. Wood burning as a source of atmospheric polycyclic aromatic hydrocarbons. *Environ. Sci. Technol.*, 24, 1581-1585.
- Gras, J.L., **1996**. "The Perth Haze Study: A Report to the Department of Environmental Protection of Western Australia on Fine-Particle Haze in Perth", CSIRO Division of Atmospheric Research, July.
- Gras, J.L., Gillet, R.W., Bentley, S.T., Ayers, G.P. and Firestone, T., **1992**. "CSIRO-EPA Melbourne Aerosol Study. Final Report", March.
- Greenberg, A., Darak, F., Harkov, R., Liroy, P. and Daisey, J., **1985**. Polycyclic aromatic hydrocarbons in New Jersey: A comparison of winter and summer concentrations over a two-year period. *Atmos. Environ.*, 19, 1325-1339.
- Grimmer, G., Brune, H., Deutsch-Wenzel, R., Naujack, K.W., Dettbarn, G., Misfeld, J., Abel, U. and Trimm, J., **1984**. *Cancer Lett.*, 23, 167-76.
- Grimmer, G., Brune, H., Deutsch-Wenzel, R., Naujack, K.W., Misfeld, J. and Trimm, J., **1983**. *Cancer Lett.*, 21, 105-113.
- Grimmer, G., Dettbarn, G., Brune, H., Deutsch-Wenzel, R. and Misfeld, J., **1982**. *Int. Arch. Occup. Environ. Health*, 50, 95-100.
- Grosjean, D., Fung, K. and Harrison, J., **1983**. *Environ. Sci. Technol.*, 17, 673-679.
- Hannigan, M.P., Cass, G.R., Penman, B.W., Crespi, C.L., Lafleur, L.A., Busby Jr., W.F., Thilly, W.G., and Simoneit, B.R.T., **1998**. Bioassay-directed chemical analysis of Los Angeles Airborne Particulate Matter, Using a Human Cell Mutagenicity Assay. *Environ. Sci. Technol.*, 32, 3502-3514.
- Harrison, R.M., Smith, D.J.T. and Luhana, L.M., **1996**. *Environ. Sci. Technol.*, 30, 825-832.
- Hart, K.M. and Pankow, J.F., **1990**. *J Aerosol Sci.*, 21, 377-380.
- Hawthorne, S.B., Krieger, M.S. and Miller, D.J. **1989**. Supercritical carbon dioxide extraction of polychlorinated biphenyls, polycyclic aromatic hydrocarbons, heteroatom-containing polycyclic aromatic hydrocarbons, and n-alkanes from polyurethane foam sorbents. *Anal. Chem.*, 61, 736-740.
- Hawthorne, S.B., Miller, D.J., Langenfeld, J.J. and Krieger, M.S., **1992**. PM-10 high-volume collection and quantitation of semi- and nonvolatile phenols, methoxylated phenols, alkanes, and polycyclic aromatic hydrocarbons from winter urban air and their relationship to wood smoke emissions. *Environ. Sci Technol.*, 26, 2251-2262.

Helmig, D., Lopez-Cancio, J., Arey, J., Harger, W.P. and Atkinson, R., **1992**. *Environ. Sci. Technol.*, 26, 2207-2213.

Hemminki, K., Grzybowska, E., Chorazy, M., Twardowska-Sauchka, K., Sroczynski, J.W., Putman, K.L., Randerath, K., Phillips, D.H. and Hewer, A., **1990**. *Int. Arch. Occup. Environ. Health*, 62, 467-470.

Hooper, M.A., Body, P.J. and Hooper, B.M., **1993**. "Coal Liquefaction: Atmospheric Impacts: A Final Report to the Coal Corporation of Victoria", Gippsland Centre for Environmental Science, Monash University, Gippsland, May.

IARC, **1987**. "Overall Evaluations of Carcinogenicity: An Updating of IARC Monographs Volumes 1 to 42", (IARC Monographs on the Evaluation of the Carcinogenic Risk of Chemical to Humans, Volume 38), International Agency for Research on Cancer, Lyon, 219 pp.

IPCS, **1998**. "Selected Non-heterocyclic Polycyclic Aromatic Hydrocarbons" Environmental Health Criteria 202, International Programme on Chemical Safety, WHO, Geneva.

ISO, **1997**. "Determination of Gas and Particle-Phase Polynuclear Aromatic Hydrocarbons in Ambient Air – Collected on Sorbent-Backed Filters with Gas Chromatographic/Mass Spectrometric Analysis," ISO/CD 12884:1997, International Organisation for Standardisation, Case Postale 56, CH-1211, Geneva 20, Switzerland.

Jacob, J. and Grimmer, G., **1979**. Extraction and enrichment of polycyclic aromatic hydrocarbons (PAH) from environmental matter. In "Environmental Carcinogens: Selected Methods of Analysis. Volume 3: Analysis of Polycyclic Aromatic Hydrocarbons in Environmental Samples", H. Egan, M. Castegnaro, P. Bogovski, H. Kunte & E.A., Walker, eds., International Agency for Research on Cancer, Lyon, pp. 79-89.

Janda, V., Bartle, K. and Clifford, A., **1993**. Review: Supercritical fluid extraction in environmental analysis. *J. Chrom.*, 642, 283-299.

Keller, C.D. and Bidleman, T.F., **1984**. Collection of airborne polycyclic aromatic hydrocarbons and other organics with a glass fibre filter-polyurethane foam system. *Atmos. Environ.*, 18, 837-845.

Kelly, G., Bartle, K., Clifford, A. and Robinson, R., **1992**. Quantitative analysis of polycyclic aromatic hydrocarbons in diesel exhaust particles using supercritical fluid extraction and on-line coupled LC-GC. *J. High Resol. Chromatogr.*, 15, 526-530.

Khalili, N.R., Scheff, P.A. and Holsen, T.M., **1995**. PAH source fingerprints for coke ovens, diesel and gasoline engines, highway tunnels and wood combustion emissions. *Atmos. Environ.*, 29(4), 533-542.

- Krewski, D., Thorslund, T. and Withey, J., **1989**. Carcinogenic risk assessment of complex mixtures. *Toxicol. Ind. Health*, 5, 851-867.
- Lafleur, A.L. and Wornat, M.J., **1988**. *Anal. Chem.*, 60, 1092-1102.
- Langenfeld, J.L., Hawthorne, S.B., Miller, D.J. and Pawliszyn, J., **1993**. Effects of temperature and pressure on supercritical fluid extraction efficiencies of polycyclic aromatic hydrocarbons and polychlorinated biphenyls. *Anal. Chem.*, 65, 338-344.
- Lao, R.C., Thomas, R.S., Oja, H. and Dubois, L., **1973**. Application of gas chromatograph-mass spectrometer-data processor combination to the analysis of polycyclic aromatic hydrocarbons and polychlorinated biphenyls. *Anal. Chem.*, 65, 338-344.
- LBS, **1995**. "The Determination of Polycyclic Aromatic Hydrocarbons in Ambient Air by GC/MS", Laboratory Services Branch, PAHAIR/APSD-E3124B, Ontario Ministry of Environment and Energy, Etobicoke, Ontario.
- Lee, M.L., Novotny, M. and Bartle, K.D., **1976**. Gas chromatography/mass spectrometric and nuclear magnetic resonance determination of polynuclear aromatic hydrocarbons in airborne particulates. *Anal. Chem.*, 48, 1566-1572.
- Lewis, A.C., Kupiszewska, D., Bartle, K.D. and Pilling, M.J., **1994**. City Centre Concentrations of Polycyclic Aromatic Hydrocarbons using Supercritical Fluid Extraction. Department of Chemistry, University of Leeds, Leeds LS2 9JT, England. <http://www.chem.leeds.ac.uk/papers/html/pahmosaic/pahmosaic.html>
- Lodge, J.P., **1988**. In "Methods of Sampling and Analysis", Lewis Publishers, Michigan.
- Lyall, R.J., and Hooper, M., **1988**. A long-term study of benzo(a)pyrene in the Latrobe Valley. *Clean Air*, 22(4), 203-204.
- Mainwaring, S.J. and Stirling, D.M., **1981**. A study of the size distribution and concentrations of polynuclear hydrocarbons in Melbourne air. In "Proceedings of the 7th International Clean Air Conference, Adelaide, Australia", K.A. Webb and A.J. Smith (Eds.), Ann Arbor, MI, Ann Arbor Science, 605-622.
- Monserrate, M. and Olesik, S., **1997**. Evaluation of SFE-CO₂ and methanol-CO₂ mixtures for the extraction of polynuclear aromatic hydrocarbons from house dust. *J. Chromatog. Sci.*, 35(2), 82-84.
- Morris, W.A., Versteeg, J.K., Bryant, D.W., Legzdins, A.E., McCarry, B.E. and Marvin, C.H., **1995**. Preliminary comparisons between mutagenicity and magnetic susceptibility of respirable airborne particle. *Atmos. Environ.* 29(23), 3441-3450.

Muller, J.F., Hawker, D.W. and Connell, D.W., **1998**. Polycyclic Aromatic Hydrocarbons in the Atmospheric Environment of Brisbane, Australia. *Chemosphere* 37(7) 1369-1383.

Muller, J.F., **1997**. "Occurrence and Distribution Processes of Semivolatile Organic Chemicals in the Atmosphere and Leaves", PhD thesis submitted to Faculty of Environmental Sciences, Griffith University, Queensland.

Muller, J. F., Hawker, D.W. and Connell, D.W., **1996a**. "Polycyclic Aromatic Hydrocarbons and Polychlorinated Dibenzodioxins and Dibenzofurans in Brisbane Air. Report 2 (Final Report)", Griffith University, Faculty of Environmental Science.

Muller, J.F., Hawker, D.W., Wermuth, U.D. and Connell, D.W., **1996b**. Field evaluation of sampling artefacts for the separate collection of vapour and particle phase PAHs with a filter adsorbent type sampling system. *Clean Air*, 30(2), 37-41.

Muller, J.F., Hawker, D.W. and Connell, D.W., **1995a**. Polycyclic aromatic hydrocarbons in Brisbane air, In "Proceedings of the 4th Australian Environmental Chemistry Conference", Darwin, July.

Muller, J.F., Hawker, D.W. and Connell, D.W., **1995b**. "Polycyclic Aromatic Hydrocarbons in Brisbane Air. Report 1 (July 94 – Jan 95)", February.

Muller, J.F., Hawker, D.W. and Connell, D.W., **1995c**. Sampling system for semivolatile organic chemicals in ambient air. In "Proceedings of the 4th Australian Environmental Chemistry Conference", Darwin, July.

Muller, P., Leece, B. and Raha, D., **1995a**. Estimated risk of cancer from exposure to PAH fractions of complex mixtures. In "15th International Symposium on Polycyclic Aromatic Compounds: Chemistry, Biology, and Environmental Impact". Belgirate, Italy, 19-22, September. Ispra Joint Research Centre European Commission, pp. 159-160.

Muller, P., Leece, B. and Raha, D., **1995b**. "Dose-Response Assessment PAH", Ontario Ministry of the Environment and Energy, Ottawa, 197 pp.

Muller, P., Leece, B. and Raha, D., **1996**. "Scientific Criteria Document for Multimedia Environment Standards Development: Polycyclic Aromatic Hydrocarbons (PAH). Part 1. Dose Response Assessment", Ontario Ministry of the Environment and Energy, Ottawa, 203 pp.

Nishioka, M.G., Petersoen, B.A. and Lewtas, J. **1982**. "PAC: Physical and Biological Chemistry", Batelle Press, Columbus, OH, pp. 603-614.

NIST, **1992**. "NIST92 Mass Spectra", National Institute of Standards and Technology, Gaithersburg, MD.

NSW EPA, **1996**. “Quarterly Air Quality Monitoring Data. Part B: Industrial Data (1-4)”, NSW Environment Protection Authority, Sydney.

NSW EPA, **1997**. “Quarterly Air Quality Monitoring Data. Part B: Industrial Data (1-4)”, NSW Environment Protection Authority, Sydney.

Ostman, C., Nilsson, U., Carlsson, H., Andersson, I, and Fahlgren, L., **1992a**. “Polycyclic Aromatic Compounds (PAC) in Work Environment. II. PAC in Stockholm Street Air: Content of PAH in Two Busy Streets. Research Report No. 34”, Swedish Institute of Occupational Health, Solna, 16 pp.

Ostman, C., Nilsson, U., Carlsson, H., Andersson, I, and Fahlgren, L., **1992b**. “Polycyclic Aromatic Compounds (PAC) in Work Environment. III. PAC in Stockholm Street Air: Content of PAH before and after a Traffic Diversion. Research Report No. 35”, Swedish Institute of Occupational Health, Solna, 31 pp.

Panther, B.C., Hooper, M.A. and Tapper, N.J., **1999**. A comparison of air particulate matter and associated polycyclic aromatic hydrocarbons in some tropical and temperate urban environments. *Atmos. Environ.*, In Press.

RIVM, **1999a**. “Environmental Risk Limits in The Netherlands”, Dutch National Institute of Public Health and the Environment (RIVM), report No. 601640 001.

RIVM, **1999b**. “Setting Integrated Environmental Quality Standards: Environmental Quality Standards for Soil, Water & Air”, Dutch National Institute of Public Health and the Environment (RIVM).

Salmeen, I.T., Pero, A.M., Zator, R., Schuetzle, D. and Riley, T.L., **1984**. *Environ. Sci. Technol.*, 18, 375-382.

Sawicki, E., **1962**. *J. Amer. Indust. Hygiene Assoc.*, 23, 137-142.

Skopek, T.R., Liber, H.L., Kaden, D.A., Hites, R.A. and Thilly, W.G., **1979**. *J. Natl. Cancer Inst.*, 63, 309-312.

Smith, D.J.T. and Harrison, R.M., **1998**. Polycyclic Aromatic Hydrocarbons in Atmospheric Particles. In “Atmospheric Particles”, R.M. Harrison and R. Van Grieken Eds., John Wiley & Sons.

Smith, D.J.T., Harrison, R.M., Luhana, L., Pio, C.A., Castro, L.M., Nawaz-Tariq, M., Hayat, S. and Quraishi, T., **1996**. *Atmos. Environ.*, 30, 4031-4040.

Stenberg, U., Alsberg, T., Blomberg, L. and Wannman, T., **1979**. Gas chromatographic separation of high-molecular polynuclear aromatic hydrocarbons in samples from different sources, using temperature stable glass capillary columns. In “Polynuclear

Aromatic Hydrocarbons”, P.W. Jones and P. Leber (Eds.), 3rd International Symposium Ann Arbor, MI, Ann Arbor Science, pp. 313-326.

Thrane, K.E. and Mikalsen, A., **1981**. *Atmos. Environ.*, 909-918.

US EPA, **1999**. Compendium Method TO-13A: Determination of polycyclic aromatic hydrocarbons (PAHs) in ambient air using gas chromatography/mass spectrometry (GC/MS). In “Compendium of Method for the Determination of Toxic Organic Compounds in Ambient Air”, 2nd edition, EPA/625/R-96/010b, Centre for Environmental Research Information, US Environmental Protection Agency, OH.

US EPA, **1990**. “Test Methods for Evaluating Solid Wastes. Physical/Chemical Methods”, United States Environmental Protection Agency, SW-846 CD-ROM Version 2.0.

US EPA, **1989**. Compendium Method TO-13: The determination of benzo(a)pyrene [B(a)P] and other polynuclear aromatic hydrocarbons (PAHs) in ambient air using gas chromatographic (GC) and high performance liquid chromatographic (HPLC) analysis. In “Compendium of Methods for the Determination of Toxic Organic Compounds in Ambient Air”, EPA/600/4-89-018, Centre for Environmental Research Information, US Environmental Protection Agency, OH.

Vanderzalm, J.L., Hooper, M.A., Maenhaut, W. and Tapper, N.J., **1998**. Particulate air quality and polycyclic aromatic hydrocarbons in regional Northwest Australia and Southeast Asia. In “14th International Clean Air & Environment Conference”, Melbourne, 18-22 October, pp. 433-438.

VicRoads/EPA, **1991**. “PAH, PM10, Total Particulate Matter and Lead Measurements at Debney’s Park Estate, Flemington, 1990-1991”, VicRoads Study, Victoria.

Victorian EPA, **1998**. “Hazardous Air pollutants—A Review of Studies Performed in Australia and New Zealand”, Environment Protection Authority, Victoria.

Wise, S.A., Chelser, S.N., Hilpert, L.R., May, W.E., Rebbert, R.E., Vogt, C.R., Nishioka, M.G., Austin, A. and Lewtas, J., **1985**. *Environ. Int.*, 11, 147-160.

Yamasaki, H., Kuwata, K. and Miyamoto, H., **1982**. *Environ. Sci. Technol.*, 16, 189-194.

Yan, C., Dadoo, R., Zhao, H., Zare, R.N. and Rakestraw, D.J., **1995**. *Anal. Chem.*, 67, 2026-2029.

Yang, S.Y.N., Connell, D.W., Hawker, D.W., and Kayal, S.I., **1991**. Polycyclic aromatic hydrocarbons in air, soil and vegetation in the vicinity of an urban roadway. *Sci. Tot. Environ.*, 102, 229-240.

Zhang, X. and McMurry, P.H., **1991**. *Environ. Sci. Technol.*, 25, 456-459.

11. Appendices

Appendix A: List of Organisations/Individuals Contacted

The following people in the various were contacted for data and information on PAH monitoring Sampling

A1. Environmental Agencies

Mr Trevor Bardsley
Victorian EPA

Mr David Wainwright
Mr Donald Neale
Queensland EPA

Mr Rob Mitchell
Mr Tom Whitworth
SA Dept. of Environment, Heritage &
Aboriginal Affairs

Mr Rick Zentelis
Mr Don Horan
Environment ACT

Dr Steve McPhail
Mr Russell Cowell
Mr Mathew Riley
NSW EPA

Dr Frank Carnovale
Tasmania Dept. Environment & Land
Management

Mr Randall Scott
NT Dept. of Lands, Planning &
Environment

A2. Other Government Agencies

Mr Phil West
VicRoads
VIC

Mr Doug Ingraham
Dr Steve Wilkinson
Chemistry Centre
Dept of Minerals and Energy
Perth, WA

Mr Wayne Riley
Mr Ian Fox
ACT Dept. of Health

A3. Research Institutions

Dr John Gras
Dr Willem Bouma
Mr Paul Holper
CSIRO Div. Atmospheric Research
Aspendale, VIC

Dr Lidia Morawska
Dr Godwin Ayoko
Environmental Aerosol Laboratory
Queensland University of Technology

Dr David Parry
Northern Territory University
Darwin, NT

Ms. Chris Thompson
CSIRO Div. of Energy Technology
Bangor, NSW

Mr Gerry Scheltinga
CSIRO Div. Molecular Science
Clayton, VIC

Mr Peter Bosci
CSIRO Petroleum Resources
N. Ryde, NSW

Dr Martin Hooper
Monash University
Gippsland Campus

Dr Jochen Muller
National Research Center for
Environmental Toxicology
University of Queensland
Brisbane, QLD

Dr Dale Hocker
Griffith University
Nathan, QLD

Dr Neville Clarke
Flinders University
Adelaide, SA

Dr John Monro
Dorothy Robinson
Air Quality Research Group
University of New England
Armidale, NSW

Appendix B: Ring Structure of Selected PAHs

Acenaphthalene

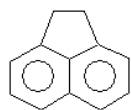

Acenaphthylene

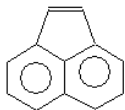

Anthracene

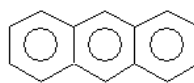

Benz(a)anthracene

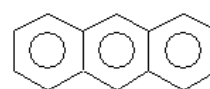

Benzo(a)pyrene

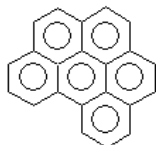

Benzo(b)fluoranthene

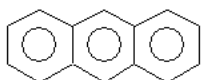

Benzo(e)pyrene

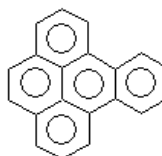

Benzo(g,h,i)perylene

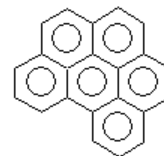

Benzo(k)fluoranthene



Chrysene

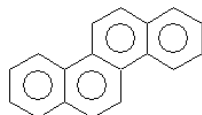

Coronene

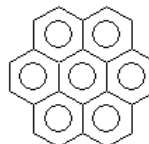

Dibenz(a,h)anthracene

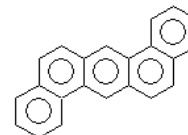

Fluoranthene

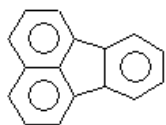

Fluorene

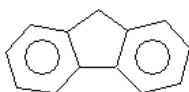

Ideno(1,2,3-c,d)pyrene

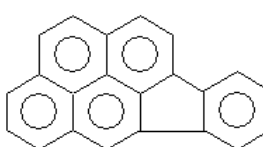

Naphthalene

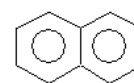

Perylene

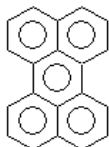

Phenanthrene

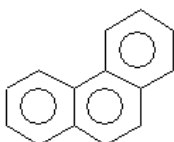

Pyrene

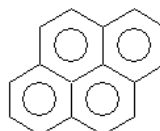

Appendix C: General Metal Works PAH Sampling Head

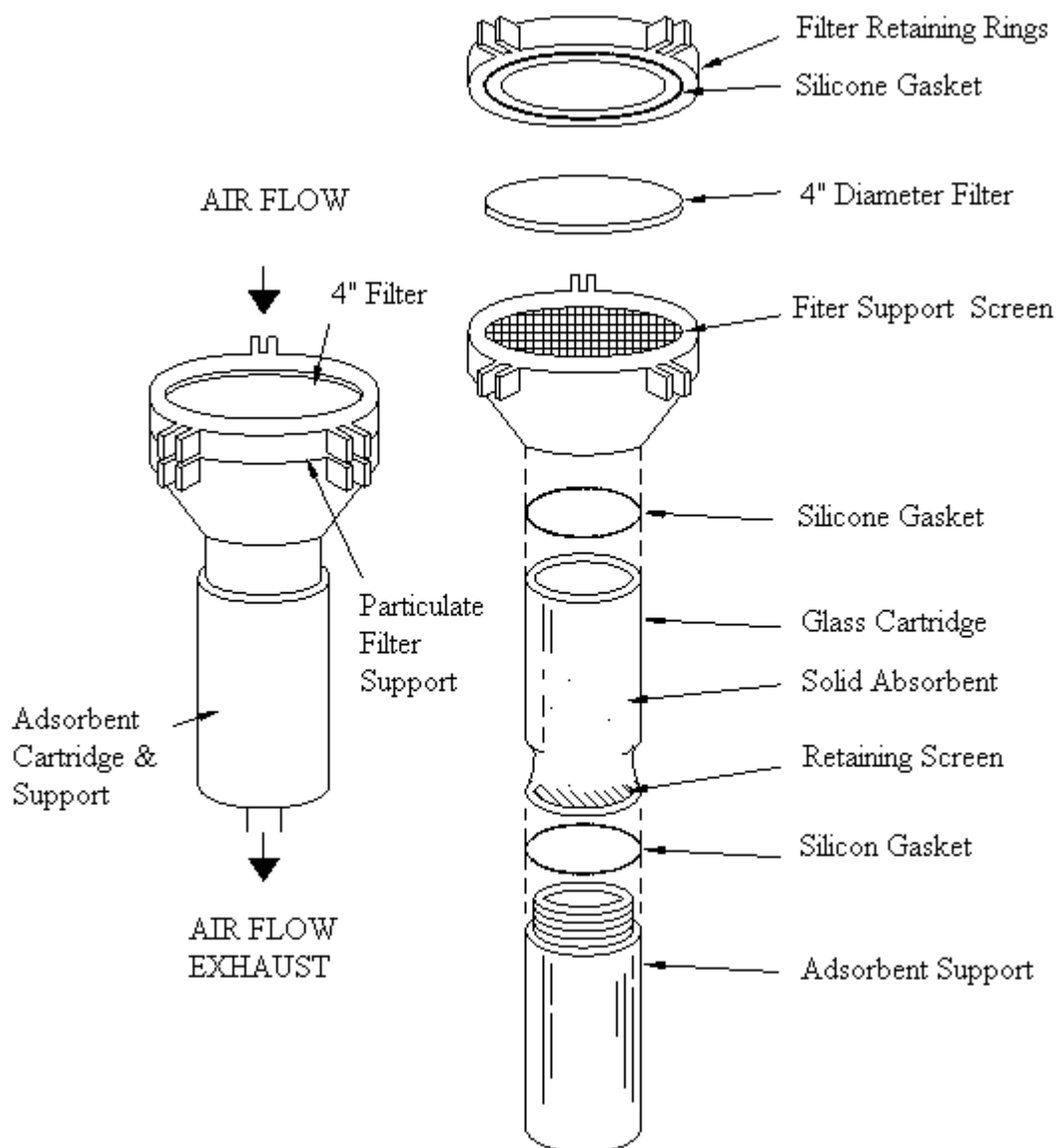

(Source: US EPA, 1989)

Appendix D: Apparatus Used in Sample Preparation

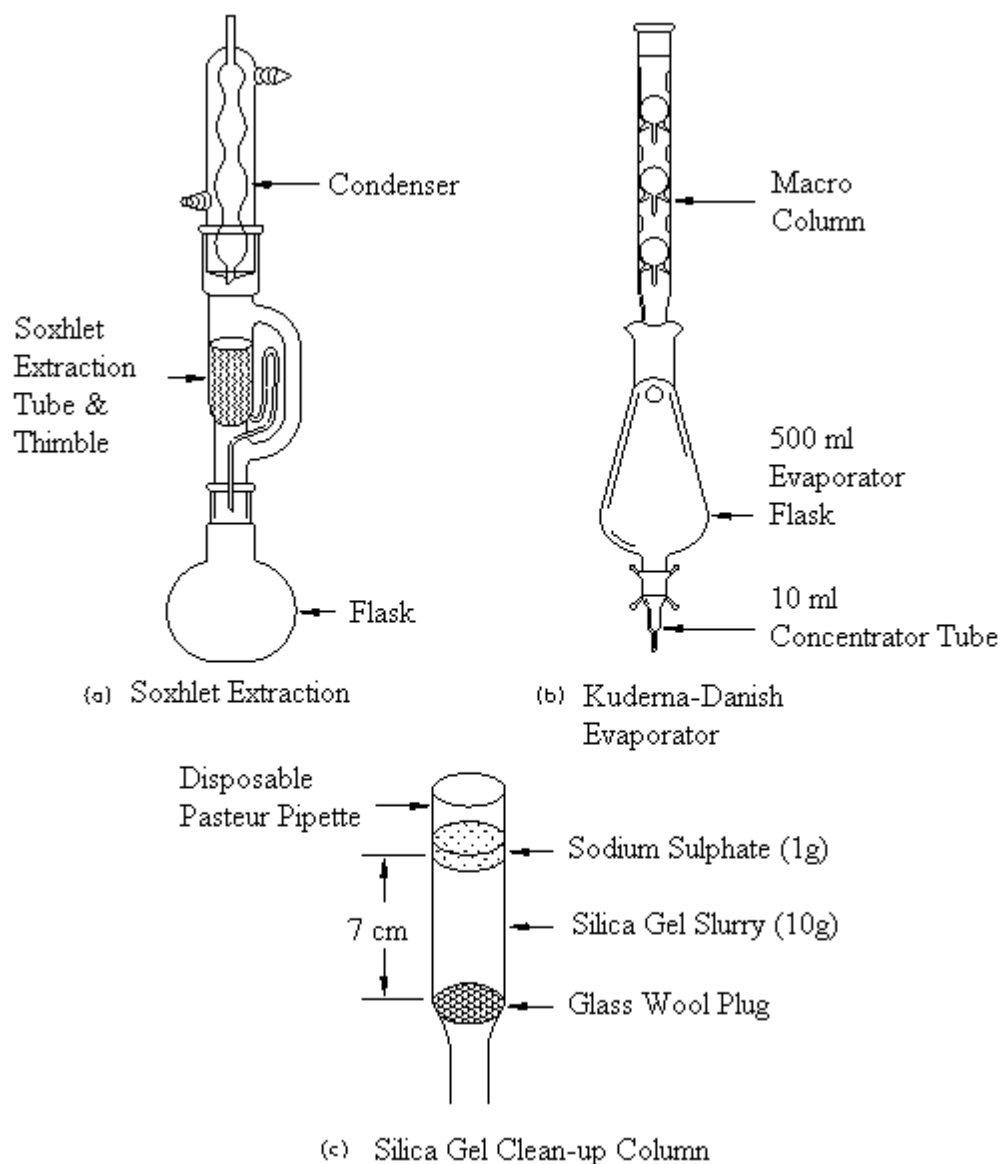

(Source: US EPA, 1989)